



Installation Guide

Energy Meter with Modbus Connection

For Europe, APAC and South Africa
Version 1.0

Disclaimers

Important Notice

Copyright © SolarEdge Inc. All rights reserved.

No part of this document may be reproduced, stored in a retrieval system or transmitted, in any form or by any means, electronic, mechanical, photographic, magnetic or otherwise, without the prior written permission of SolarEdge Inc.

The material furnished in this document is believed to be accurate and reliable. However, SolarEdge assumes no responsibility for the use of this material. SolarEdge reserves the right to make changes to the material at any time and without notice. You may refer to the SolarEdge web site (www.solaredge.com) for the most updated version.

All company and brand products and service names are trademarks or registered trademarks of their respective holders.

Patent marking notice: see <http://www.solaredge.com/patent>

The general terms and conditions of delivery of SolarEdge shall apply.

The content of these documents is continually reviewed and amended, where necessary. However, discrepancies cannot be excluded. No guarantee is made for the completeness of these documents.

The images contained in this document are for illustrative purposes only and may vary depending on product models.

Emission Compliance

This equipment has been tested and found to comply with the limits applied by the local regulations.

These limits are designed to provide reasonable protection against harmful interference in a residential installation. This equipment generates, uses and can radiate radio frequency energy and, if not installed and used in accordance with the instructions, may cause harmful interference to radio communications. However, there is no guarantee that interference will not occur in a particular installation. If this equipment does cause harmful interference to radio or television reception, which can be determined by turning the equipment off and on, you are encouraged to try to correct the interference by one or more of the following measures:

- Reorient or relocate the receiving antenna.
- Increase the separation between the equipment and the receiver.
- Connect the equipment into an outlet on a circuit different from that to which the receiver is connected.
- Consult the dealer or an experienced radio/TV technician for help.

Changes or modifications not expressly approved by the party responsible for compliance may void the user's authority to operate the equipment.

Version History

- Version 1.0 (August 2019) - Initial release

Contents

Disclaimers	1
Important Notice	1
Emission Compliance	2
Contents	5
HANDLING AND SAFETY INSTRUCTIONS	7
Safety Symbols Information	7
Chapter 1: The SolarEdge Energy Meter with Modbus Connection	9
Package Contents	10
Terminology	11
Metering Applications	12
Meter Connection Options	14
Meter Interfaces	15
Chapter 2: Meter Installation	19
Installation Guidelines	19
Installing and Connecting the Meter	21
Chapter 3: Configuration	31
SolarEdge Device Firmware Version	31
Device Configuration	33
Appendix A: Troubleshooting the Meter	39
Communications Failure	39
The Energy Value is not Advancing	42
Appendix B: Installing Two Meters	44
Connecting Two Meters	44

Configuring the Dual-Meter Connection	46
Verifying the Dual-Meter Connection	48
Troubleshooting the Dual-Meter Connection	48
Appendix C: Monitoring Platform - Meter Data	49
Appendix D: External Lightning Protection	53
Appendix E: Meter Technical Specifications	55
Support Contact Information	58

HANDLING AND SAFETY INSTRUCTIONS

During installation, testing and inspection, adherence to all the handling and safety instructions is mandatory. **Failure to do so may result in injury or loss of life and damage to the equipment.**

Safety Symbols Information

The following safety symbols are used in this document. Familiarize yourself with the symbols and their meaning before installing or operating the system.

WARNING!



Denotes a hazard. It calls attention to a procedure that, if not correctly performed or adhered to, could result in **injury or loss of life**. Do not proceed beyond a warning note until the indicated conditions are fully understood and met.

CAUTION!



Denotes a hazard. It calls attention to a procedure that, if not correctly performed or adhered to, could result in **damage or destruction of the product**. Do not proceed beyond a caution sign until the indicated conditions are fully understood and met.



NOTE

Denotes additional information about the current subject.



IMPORTANT SAFETY FEATURE

Denotes information about safety issues.

Disposal requirements under the Waste Electrical and Electronic Equipment (WEEE) regulations:



NOTE

Discard this product according to local regulations or send it back to SolarEdge.

Chapter 1: The SolarEdge Energy Meter with Modbus Connection

The SolarEdge Energy Meter with Modbus Connection (also referred to as “the meter”) enables measuring the power and energy of the photovoltaic (PV) system.

The meter is used by the inverter for the following applications:

- Production metering
- Consumption monitoring
- Export limitation
- Smart Energy on-grid applications

The meter supports both single-phase and three-phase grids, and requires the installation of Current Transformers (CTs). The CTs are available from SolarEdge:

- When used in a single-phase grid, one CT is required.
- When used in a three-phase grid, three CTs are required.

NOTE

This installation guide is for connection of the meter to inverters using SetApp.



An installation guide for connection of the meter to inverters using a display is available for download from: <https://www.solaredge.com/sites/default/files/solaredge-meter-installation-guide-dispaly-row.pdf>

Package Contents

- SolarEdge Energy Meter with Modbus Connection
- Two DIN rail adapters
- Four screws
- Installation Guide

Terminology

The following terms are used in this document:

- **Export:** The power injected to the grid.
- **Import:** The power purchased from the grid.
- **Export/Import meter:** A meter that is installed at the grid connection point and measures the energy/power exported/imported to/from the grid.
- **Consumption:** The power consumed at the site. Consumption power is calculated as the sum of self-consumption power and import power.
- **Consumption meter:** A meter that is installed at the load consumption point and measures the energy/power consumed by the site.
- **Self-consumption:** The PV power consumed by the site and not fed into the grid.
- **Production:** The power produced by the PV system.
- **Production meter:** A meter that is installed at the inverter output or site AC connection, and measures the energy/power produced by the PV system or site.

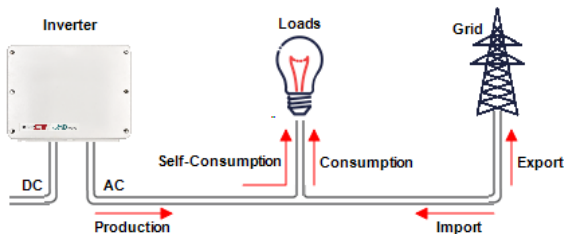

Figure 1: Terminology Illustration

Metering Applications

The SolarEdge inverter or the Commercial Gateway reads data from the meter, typically using one of the scenarios illustrated in the figures below:

- Power production from a meter installed at the output power connection of the inverter
- Exported/imported power from a meter installed at the grid connection point
- Power consumption from a meter installed at the load consumption point

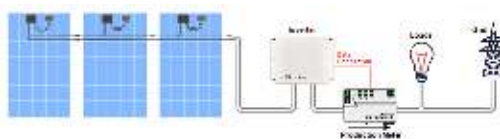

Figure 2: Typical installation with production meter



Figure 3: Typical installation with export/import meter

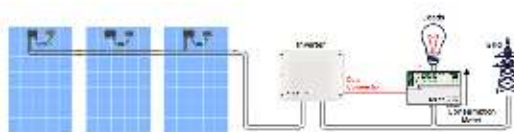

Figure 4: Typical installation with consumption meter

Meter Connection Options

In a *single* inverter system, the meter is connected directly to an RS485 port of the inverter.

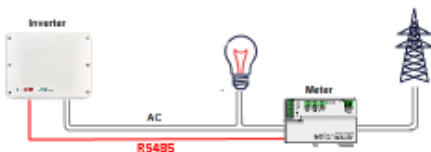

Figure 5: Single-inverter connection

In a *multiple* inverter system, two options are available:

- The meter is connected to an RS485 port of one of the inverters.
 - If the inverter has a second RS485 port, use this port to connect between the inverters.
 - If the inverter has only one RS485 port, use an RS485 Plug-In (available from SolarEdge) or ZigBee communication between the inverters.
- The meter is connected to one of the RS485 ports of a Commercial Gateway. The Commercial Gateway's second RS485 port can be used to create an RS485 bus for communication between the inverters. This option is illustrated in *Figure 6*.

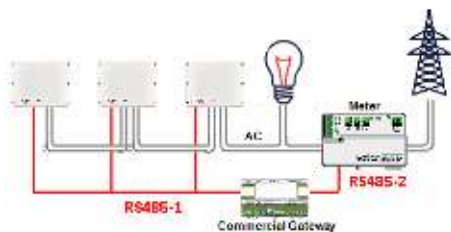

Figure 6: Multi-inverter connection with Commercial Gateway and meter

Meter Interfaces

This section describes the SolarEdge meter's interfaces.

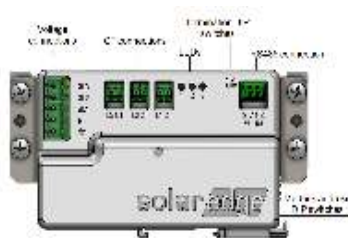

Figure 7: Meter Interfaces

- **Voltage connections:** for connection to the grid
- Wye: L1, L2, L3, N, Ground

- **CT connections** (L1 CT, L2 CT, L3 CT): for connection to current transformers
- **RS485**: for connection to the inverter/gateway
- **LEDs**: used to monitor meter status.
- **Modbus address DIP switches** (ID 1, 2, 3): used to set the Modbus address.
- **Termination DIP switches** (TERM 1, 2): used to set RS485 termination.

LEDs

The meter utilizes the LEDs in the front of the unit in order to indicate current status.

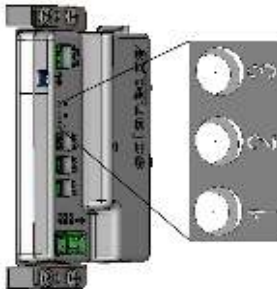

Figure 8: Meter LEDs

LED #	LED	Function	Indication
1	Green	Operational status	Blinking ON/OFF - normal operation
2	Yellow	RS485 Modbus communication	Blinking ON/OFF - communication OK
3	Yellow	Energy management	Single blink when the meter reads an energy change of ~1 kWh.

DIP Switches

Modbus Address DIP Switches

The Modbus address DIP switches are used to set the Modbus address of the meter. The addressing options are listed in the table below. See the figure *Modbus Address and Termination DIP Switches* on page 18 for switch direction guidelines.

Modbus Address	Switch 1	Switch 2	Switch 3
0	Down	Down	Down
1	Up	Down	Down
2 (factory default)	Down	Up	Down
3	Up	Up	Down
4	Down	Down	Up
5	Up	Down	Up
6	Down	Up	Up
7	Up	Up	Up

Termination DIP Switches

The Termination DIP switches are used to configure RS485 wiring termination. The termination options are listed in the table below. See the figure *Modbus Address and Termination DIP Switches* on page 18 for switch direction guidelines.

RS485 Termination	TERM 1	TERM 2
Terminated	Down	Down
Not Terminated (factory default)	Up	Up

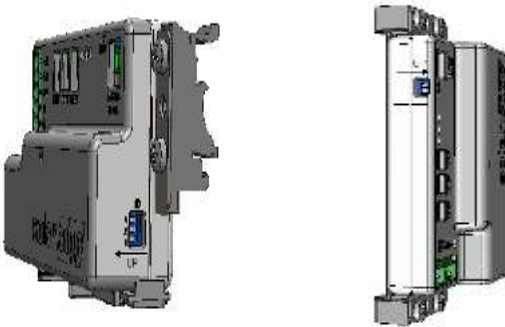

Figure 9: Modbus Address and Termination DIP Switches

Chapter 2: Meter Installation

Installation Guidelines

AC wire specifications: 1.3 to 2.0 mm diameter stranded wire, 600 V, type THHN, MTW, or THWN.

RS485 wiring specifications:

- Cable type: Min. 3-wire shielded twisted pair (a 4-wire cable may be used)
- Wire cross-section area: 0.2- 1 mm² (a CAT5 cable may be used)

NOTE



If using a cable longer than 10 meters in areas where there is a risk of induced voltage surges by lightning, it is recommend to use external surge protection devices. For details refer to *External Lightning Protection* on page 53. If grounded metal conduits are used for routing the communication wires, there is no need for a lightning protection device.

- The meter is considered “permanently connected equipment” and requires a disconnect means (circuit breaker, switch, or disconnect) and overcurrent protection (fuse or circuit breaker).

- The meter draws 10-30 mA, therefore the rating of any switches, disconnects, fuses, and/ or circuit breakers is determined by the wire gauge, the mains voltage, and the current interrupting rating required.
- The switch, disconnect, or circuit breaker must be located near the meter and be easily operated .
- Use circuit breakers or fuses rated for 20A or less.
- Use grouped circuit breakers when monitoring more than one line.
- The circuit breakers or fuses must protect the mains terminals labeled L1, L2, and L3. In the rare case in which neutral has overcurrent protection, the overcurrent protection device must interrupt both neutral and the ungrounded conductors simultaneously.
- The circuit protection / disconnect system must meet IEC 60947-1 and IEC 60947-3, as well as all national and local electrical codes.

Installing and Connecting the Meter

Mount the meter either directly on a flat surface, or on a DIN rail.

→ To mount the meter directly on a surface:

1. Using a pencil, mark the drill positions on the surface, using the four mounting holes (specified in the figure below) on the sides of the meter as a guide.

NOTE



Do not use the meter as a drilling guide; the drill may damage the screw terminals and metal shavings may fall into the connectors.



Figure 10: Meter mounting holes

2. Use the supplied screws to mount the meter. Do not over-tighten the screws, as it may damage the brackets.

→ To mount on a DIN rail using clips:

The supplied kit includes two DIN-rail adapters and four screws.

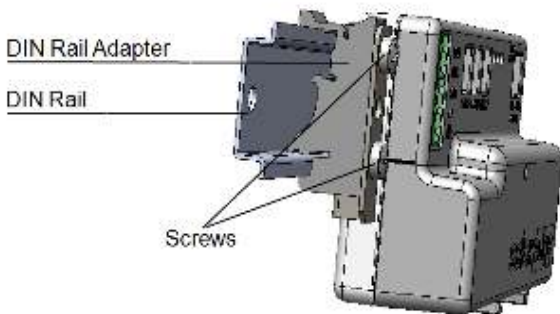

Figure 11: Mounting the meter on a DIN-rail

1. Attach the DIN-rail adapters to the DIN rail.
2. Connect the meter to the DIN-rail adapters, and fasten them using the supplied screws.

Alternative DIN-rail mounting methods - using different combinations of mounting holes, or upside down - are depicted in the figure below.

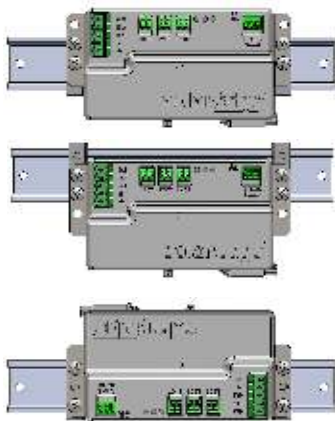

Figure 12: Alternative DIN-rail mounting

→ To detach the meter from the DIN rail:

To detach the meter from the DIN rail, insert a flat-head screwdriver into the release slot of the DIN-rail adapter shown below, and turn the screwdriver to detach the adapter from the rail.

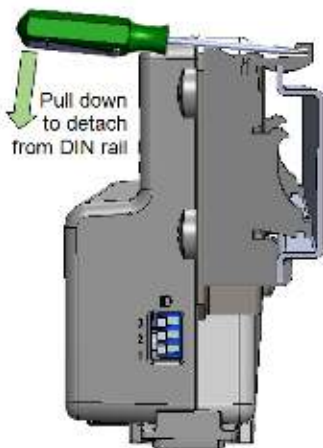

Figure 13: Detaching the meter from the DIN rail

→ To install the current transformers (CTs):



NOTE

If the meter is to be used for production, make sure to choose CTs that are appropriate for use with a production meter.

1. Turn off AC power before clamping on current transformers.
2. Install the CTs around the conductor to be measured. Split-core CTs can be opened for installation around a conductor. A nylon cable tie may be secured around the CT to prevent accidental opening.
3. Install the CTs with the arrows pointing to the grid for consumption or export measurement.

→ To wire the meter:

The meter communicates with the inverter/Commercial Gateway over an RS485 connection. Wire the meter in accordance with the three-phase connection diagrams below.

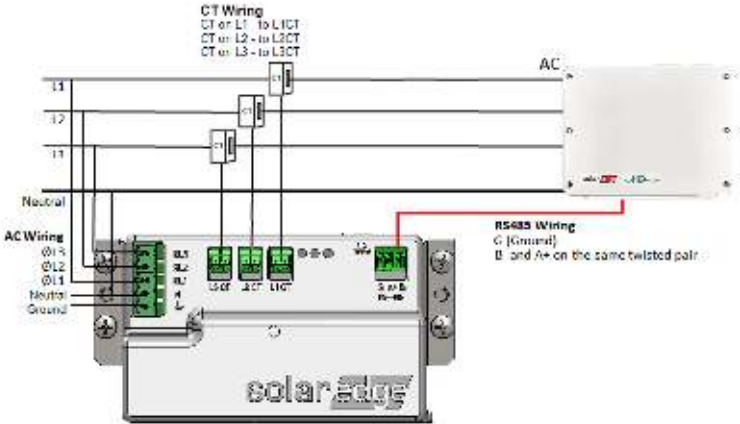

Figure 14: Three Phase Grid (Wye) - Production Meter Connections

NOTE

- Clamp the CT connected to **L1 CT** around the wire connected to **ØL1**.
- Clamp the CT connected to **L2 CT** around the wire connected to **ØL2**.
- Clamp the CT connected to **L3 CT** around the wire connected to **ØL3**.

1. Verify that power is OFF before making connections.
2. Connect the AC side wires (meter input) to the grid connectors on the meter.
3. Connect the CT wires to the three 2-pin terminals on the meter.

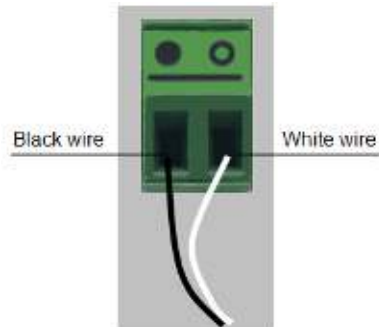

Figure 15: Wiring the CTs

4. Connect the RS485 twisted pair cable to the 3-pin terminal on the meter:
 - a. Connect the wires to the A+ and B- terminals, and connect the shield to the G terminal.
5. Set the meter's DIP switches as follows. For general DIP switch guidelines, see "DIP Switches" on page 17
 - a. Set the termination DIP switches for **Termination**. Both switch 1 and switch 2 should be in the DOWN position.
 - b. Set the address DIP switches for **Modbus Address 2**: Set switch 2 to UP, and set switches 1 and 3 to DOWN.

→ To connect the meter to the inverter or Commercial Gateway:

1. Prepare to connect to one of the available RS485 ports of the device, as shown below:
 - Inverter RS485-1 - pull out the RS485 connector located on the communication board.



Figure 16: Inverter RS485 connectors

- Commercial Gateway - use one of the 3-pin connectors supplied with the Commercial Gateway. Connect it to the RS485-2 connection on the Commercial Gateway, as shown in the figure below.

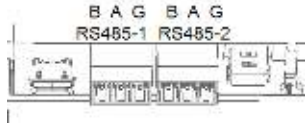

Figure 17: RS485 connectors on the Commercial Gateway

2. Connect the meter's RS485 G, A+, and B- connectors to the G, A, and B connectors in the inverter.
3. If the SolarEdge device is at the end of the RS485 bus, terminate as follows:
 - Inverter - Terminate by switching a termination DIP-switch inside the inverter to ON (top position).



Figure 18: RS485 termination switch on inverter

- Commercial Gateway - Terminate by switching the SW2 termination DIP-switch to ON.

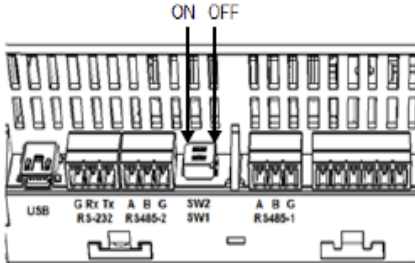

Figure 19: RS485 termination switch on Commercial Gateway

Chapter 3: Configuration

SolarEdge Device Firmware Version

To ensure proper communication with the meter, make sure that the inverter communication board firmware (CPU) version is 4.2.xx or later.

NOTE



If the inverter uses an earlier version, it will automatically upgrade the CPU to the required version upon connection of the inverter to the internet. In the event that a manual upgrade is required, open SetApp and follow the upgrade instructions.

→ To check the inverter CPU version:

1. Select **Commissioning** → **Information** to view the CPU Version.

Information	
CPU Version	4.2000.0000
DSP1 Version	1.0210.1066
DSP2 Version	2.0052.0410
Serial Number	7F129A09-33
Hardware IDs	>
Error Log	>
Warning Log	>

Device Configuration

This section describes basic configuration of SolarEdge devices (inverter/Commercial Gateway) for use of a meter. In addition, a configuration that is specific to the application being used is required in some cases. Refer to the following documents:

- Export Limitation - https://www.solaredge.com/sites/default/files/feed-in_limitation_application_note.pdf
- StorEdge Smart Energy Management on-grid applications - https://www.solaredge.com/sites/default/files/se_storedge_interface_installation_guide_for_hd_wave_setapp_and_lg.pdf

NOTE

Calculated meter readings, such as self-consumption, are calculated using the data measured by the meter and the inverters. Calculated meter readings are only sent when Energy Manager is enabled (for details refer to



https://www.solaredge.com/sites/default/files/feed-in_limitation_application_note.pdf).

Device Configuration using SetApp



NOTE

Meter functionality is supported in inverters with CPU versions 4.2.xxx and above.

→ To configure the SolarEdge meter using SetApp:

1. From the SetApp main menu, select **Communication** or **Monitoring Communication** (depending on your SetApp version), and select the port to which the meter is connected - **RS485-1** or **RS485-2**.
2. Select **Protocol >> Modbus (Multi-Device)**
3. Return to the RS485-x Menu and select **Add Modbus Device >> Meter**. A meter identified as "Meter n" (where n = 1, 2, 3...) is created. The RS485-x Menu reappears.
4. Select **Meter n**. The RS485-x Meter n Menu appears.
5. Select **Meter Function**, and choose one of the following options:
 - **Inverter Production:** The meter is installed at the inverter output and reads the energy produced by the inverter.
 - **Export+Import:** The meter is installed at the grid connection point and reads pulses from both directions - export and import energy.

- **Consumption:** The meter is installed at the load consumption point and reads the energy consumed by the site.
 - **Site Production:** The meter is installed at the inverter output and reads the energy produced by inverters at the site.
 - **Ext. Production:** The meter is used for export limitation with 3rd party generators and for AC coupling with non-SolarEdge inverters.
6. Select **Meter Protocol**, and select **SolarEdge**.
 7. Select **Device ID** and enter the Modbus address corresponding to the ID DIP switch settings on the meter.
 8. Select **CT Rating** and enter the current transformer's rating in amperes.
 9. Select **Grid Topology** and select **Wye**.
 10. If relevant, select **PT Scaling** and set the potential transformer ratio. The default value is 1.

Verifying the Meter Connection

Verifying the Meter Connection using SetApp

→ To verify the meter connection using SetApp:

1. From the SetApp main menu, select **Status**.
2. On the Status page, scroll down to the **Communication** status section. Check that one or more meters is connected to the RS485-1 or RS485-2 bus.

Communication		
LAN Connected	RS485-1 Modbus 2 of 2	RS485-2 SE Slave None
Cellular N/A	Wi-Fi NC	ZigBee NC

3. Continue scrolling to the **Meters** section. If there is more than one meter/function, there is a status sub-section for each one. An example appears below. The following information is displayed:

- **Type and function:** Displays the meter functionality (Production, Export, Import, Export+Import)
- **Status:**
 - Displays 'OK' if the meter is communicating with the inverter.
 - **<Error message>**: If an internal meter error occurs, it will be displayed here. Refer to *Troubleshooting the Meter* on page 39.
- **Power:** The exported or imported power
- **Energy:** The total energy read by the meter

Meters	
Production Meter	
SN: XXXXXXXX	
RS485-2	Status
Modbus ID #2	OK
Power	Energy
7.60 kW	13.68MWh

4. From the SetApp main menu, select **Status**.

Accessing the Meter Serial Number

Accessing the Meter Serial number using SetApp

→ To display the meter serial number using SetApp:

1. From the SetApp main menu, select **Information**.
2. On the Information page, select **Hardware IDs**. The meter serial number is found in the **RGM** field.

HW IDs	
This inverter	7F129A09-33
RGM 1	161901057
Battery 1	T16F0009749

Appendix A: Troubleshooting the Meter

This appendix describes how to troubleshoot meter-related installation and performance issues.

Communications Failure

The following are indications of a connectivity failure between the inverter and the meter:

- If **NC** (not connected) appears for a meter in the RS485-1 or RS485-2 sub sections of the Communication page, the meter is not communicating with the inverter.

Communication		
LAN Connected	RS485-1 Modbus 2 of 2	RS485-2 SE Slave None
Cellular N/A	Wi-Fi NC	ZigBee NC

- If the following error message appears in the bottom left-hand corner of the Inverters section of the Status page:
"Error 3x6E: Meter Comm. Error"
- If the status in the Meters section of the Status page is
"Comm. Error"

Meters	
Export Meter	
RS485-1	Status
Modbus ID #2	Comm. Error
Power	Energy
7.60 kW	8.42 MWh

Check the following:

- That the meter is powered on. This is indicated by a blinking green LED.
- The meter's RS485 address DIP switch settings. Refer to "DIP Switches" on page 17.
- The meter's Termination DIP switch settings. Refer to "Termination DIP Switches" on page 18.

- That the meter is configured as required in the chapter "Configuration" on page 31
- The RS485 wiring between the meter and the inverter/Commercial Gateway as specified in *To connect the meter to the inverter or Commercial Gateway*: on page 28
- There are no loose connections at the inverter connectors and at the meter, specifically the RS485 wiring.
- Check for water damage or sealing problems:
 - Inspect the entire conduit run for possible points of water penetration, and fix leaks.
 - Ensure that proper outdoor rated components are used.
- Use a Voltmeter to measure the voltage on the meter's AC wiring. The line to line voltage should be according to the meter's specifications.

The Energy Value is not Advancing

Check the Energy value in the Meters section of the Status page, as shown in the figure below:

Meters	
Export Meter	
RS485-1	Status
Modbus ID #2	Comm. Error
Power	Energy
7.60 kW	8.42 MWh

If the Energy [in MWh] value displays a steady value even though the site is consuming power, check the following:

- There are no loose connections at the inverter connectors and at the meter, specifically the AC wiring on the meter's AC wiring connector.
- The CT black and white cables are correctly connected to the CT connectors on the meter.
- That the CTs are connected to the specific phase that they are intended to measure. That is, the L1 CT should be connected to the ØL1 connector on the meter, the L2 CT to the ØL2 connector, and the L3 CT to the ØL3 connector.

- The L1/L2/L3 AC power cables pass through the CTs in the correct direction. The arrow on the inside of the CT should point in the direction of the current source.
- Check for water damage or sealing problems:
 - Inspect the entire conduit run for possible points of water penetration, and fix leaks.
 - Ensure that proper outdoor rated components are used.

Appendix B: Installing Two Meters

You can connect up to two meters on the same bus.

To connect two meters, install two wires into each screw terminal by twisting the wires together, inserting them into terminal, and securely tightening. RS485 wiring is daisy-chained between meters, as described in the following figure:

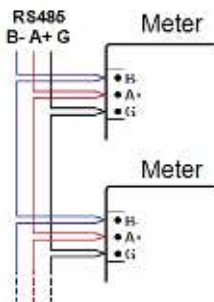

Figure 20: RS485 chain of meters

Connecting Two Meters

1. Connect the twisted pair wiring to the meters as shown in *Appendix B*.
2. Wire the RS485 connections between the meters and the inverter or Commercial Gateway.
3. Set the meters' 120 ohm termination DIP switches as

follows. For general DIP switch guidelines, see "DIP Switches" on page 17.

- a. For the meter closest to the inverter, the meter should be set for **No Termination**. Both switch 1 and switch 2 should be in the UP position.
 - b. For the meter furthest from the inverter, the meter should be set for **Termination**. Both switch 1 and switch 2 should be in DOWN position.
4. Set the meters' address DIP switches as follows. For general DIP switch guidelines, see "DIP Switches" on page 17.
- a. For one meter, set the address DIP switches for **Modbus Address 1**: Set switch 1 to UP, and set switches 2 and 3 to DOWN.
 - b. For the other meter, set the address DIP switches for **Modbus Address 2**: Set switch 1 to DOWN, set switch 2 to UP, and set switch 3 to DOWN.

Configuring the Dual-Meter Connection

Configuring Dual-Meter Connection Using SetApp

In the sample configuration described below, a production meter is set to address 1 and an export/import meter is set to address 2.

→ To configure the SolarEdge device using SetApp:

1. Verify that the meter at address 1 is configured as a production meter. From the SetApp main menu, select **Communication → RS485-x → Meter 1**
2. Verify the value of the following parameters:
 - **Meter Function → Inverter Production**
 - **Protocol → SolarEdge**
 - **Device ID → 1**
3. Select **Meter 2** to configure the export/import meter in the following steps:

4. Select **Meter Function**, and choose **Export+Import** from the following options:
 - **Export+Import:** The meter is installed at the grid connection point and reads energy from both directions - export and import.
 - **Consumption:** The meter is installed at the load consumption point and reads the energy consumed by the site.
 - **Site Production:** The meter is installed at the inverter output and reads the energy produced by the inverters at the site.
 - **Ext. Production:** The meter is used for export limitation with 3rd party generators and/or for AC coupling with non-SolarEdge inverters.
5. Select **Meter Protocol**, and select **SolarEdge**.
6. Set **Device ID** to the address 2 (the address should correspond to the DIP switch settings).
7. Select **CT Rating** to set the CT rating to the value that appears on the CT. If the displayed rating is 0 or you cannot change the value, there is no communication with the meter. Check that the AC power to the meter is on.
8. Select **Grid Topology** and select **Wye**.

9. If used, select **PT Scaling** and set the potential transformer ratio.

Verifying the Dual-Meter Connection

Verifying the Dual-Meter Connections using SetApp

To verify the connectivity of two meters using SetApp, refer to "Verifying the Meter Connection using SetApp" on page 36

Troubleshooting the Dual-Meter Connection

Troubleshooting Dual-Meter Connections using SetApp

To verify the connectivity of two meters using SetApp, refer to "Troubleshooting the Meter " on page 39

Appendix C: Monitoring Platform - Meter Data

If your device is connected to the SolarEdge server, you can view the meter's readings in the monitoring platform. Verify that the meter type is set correctly in the Admin page > Logical Layout > Meter details:



Figure 21: Setting the Meter details in the monitoring platform

Calculated meter readings (also referred to as "virtual meters"), such as self-consumption, are calculated using the data measured by the meter and the inverters.

The data from the inverters and from installed meters is displayed in the Dashboard and Charts tabs of the monitoring platform. The displayed data depends on the meter(s) location: grid connection point (export), or load consumption point (consumption). The following tables detail the displayed information per meter location.

No meter installed:

Data	Displayed in Monitoring Dashboard	Displayed in Monitoring Charts
Production (inverter/site)	✓	✓
Consumption	X	X
Self-consumption	X	X
Export	X	X
Import	X	X

Export meter:

Data	RS485 Meter	
	Displayed in Monitoring Dashboard	Displayed in Monitoring Charts
Production (inverter/site)	✓	
Consumption	✓ (calculated) (1)	✓ (calculated) (1)
Self-consumption	✓ (calculated)	✓ (calculated)
Export	X	✓
Import	X	✓

(1) Available from CPU version 2.10xx/3.14xx

Consumption meter:

Data	RS485 Meter	
	Displayed in Monitoring Dashboard	Displayed in Monitoring Charts
Production (inverter/site)	✓	✓
Consumption	✓	✓
Self-consumption	✓ (calculated)	✓ (calculated)
Export	X	✓ (calculated)
Import	X	✓ (calculated)

Appendix D: External Lightning Protection

Protection devices are most often installed from each data line to the local earth ground, and should be selected to begin conducting current at a voltage as close to the system's normal communication level as possible, but never lower. For RS485 communication lines, the selected voltage rating is typically 6-8 V. Transient suppressors should be installed as close as possible to the port that is being protected, and the user must provide an extremely low impedance connection to the local earth ground of the SolarEdge device. This ground connection is crucial for proper suppression device operation. The ground connection should be made using a heavy gauge wire and kept as short as possible. If the cable between the SolarEdge device and the protection device must be longer than 1m/3.3 ft., a copper strap or a braided cable intended for grounding purposes must be used for the protection device to be effective. In addition to the high frequency nature of transients, extremely high current may flow.

A protective device with surge discharge ratings of **In**: 10kA 8/20 μ s and **I_{max}**: 20kA 8/20 μ s is recommended.

For further information, see the *Overvoltage Surge Protection Technical Note*:

https://www.solaredge.com/sites/default/files/lightning_surge_protection.pdf

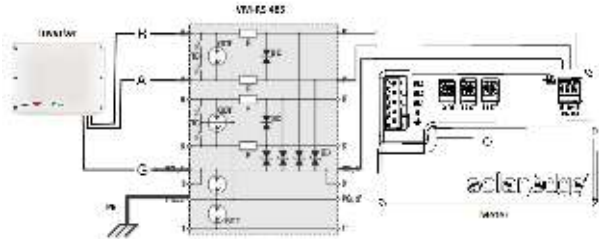

Figure 22: Protection connection

Appendix E: Meter Technical Specifications

SE-MTR-3Y-400V-A		
ELECTRICAL		
Operating Voltage Range - Line to Neutral / Line to Line	Nominal: 230/400 184-264.5 / 320-460	Vac
AC Frequency	45/65	Hz
Grids Supported ⁽¹⁾	Wye: Single Phase - L / N / PE Wye: Three Phase - L1 / L2 / L3 / N / PE	
Power Consumption (max.)	3	W
COMMUNICATION		
Supported Communication Interfaces	RS485 half-duplex, 3 wires (A, B, GND)	
Response time ⁽²⁾	≤ 200	ms
Default Device ID (Modbus)	2	
RS485 Termination	120	ohm

(1) PE (Protective Earth) connection is not required for meter operation.

(2) For power limitation applications, in which the meter is connected at grid connection point, and RS485 is used to connect multiple inverters.

ACCURACY (@ 25°C, PF: 1)⁽¹⁾		
1% - 100% of Rated CT Current	±1.0	%
IEC Accuracy	IEC 62053-21 Class 1, IEC 62053-23 Class 2	
STANDARD COMPLIANCE		
Safety	IEC 61010-1, UL 61010-1, CAN/CSA-C22.2 No. 61010-1-04	
Immunity	EN 61326: 2000, EN 61000-4-2, EN 61000-4-3, EN 61000-4-4, EN 61000-4-5, EN 61000-4-6, EN 61000-4-11	
Emissions	EN 55022 Class B	
INSTALLATION SPECIFICATIONS		
Dimensions (HxWxD)	75 x 138.6 x 35	mm
Weight	0.20	gm
Operating Temperature Range	-40 to +85	°C
Relative Humidity (noncondensing)	5% to 90% up to 40°C decreasing linearity to 50% RH at 55°C	%
Protection Rating	IP20 - Suitable for indoor use	
Mounting Type	DIN rail / Surface mount	

⁽¹⁾Using SE-ACT-0750 CT models

CURRENT TRANSFORMERS ⁽¹⁾		
Nominal Input (at CT Rated Current) - CT1, CT2, CT3: 0.333 Vac RMS		
CURRENT TRANSFORMER MODEL ⁽²⁾	RATED RMS CURRENT (A)	DIMENSIONS (INTERNAL/ EXTERNAL) (mm)
SE-CTML-0350-070	70	9.0 x 8.9 / 42.4 x 30.5
SE-ACT-0750-50	50	20 x 20 / 61 x 60.4
SE-ACT-0750-100	100	
SE-ACT-0750-250	250	
SE-CTS-2000-1000	1000	50.8 x 50.8 / 121 x 127
SE-CTB-4X4-1200	1200	102 x 102 / 158 x 168
SE-CTB-4X4-2000	2000	102 x 102 / 158 x 168
SE-CTB-4X4.5-3000	3000	102 x 114 / 171 x 168

(1) Current transformers should be ordered separately.

(2) One current transformer required per phase. For other ratings contact SolarEdge.

Support Contact Information

If you have technical problems concerning SolarEdge products, please contact us:



<https://www.solaredge.com/service/support>

Before contact, make sure to have the following information at hand:

- Model and serial number of the product in question.
- The error indicated on the product SetApp mobile application or on the monitoring platform or by the LEDs, if there is such an indication.
- System configuration information, including the type and number of modules connected and the number and length of strings.
- The communication method to the SolarEdge server, if the site is connected.
- The product's software version as it appears in the status screen.

solar**edge**