

1. Overview

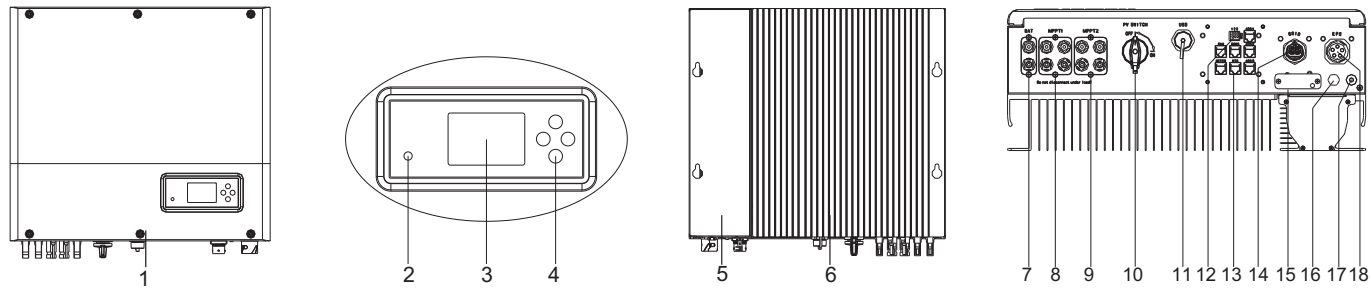

- 1. Front panel
- 2. Double color LED
- 3. LCD screen
- 4. Push button
- 5. Magnetic devices
- 6. Heat sink
- 7. Battery connector
- 8. PVA connector
- 9. PVB connector
- 10. PV switch
- 11. USB port
- 12. Dry connector
- 13. Communication ports
- 14. AC grid connector
- 15. Reserved hole
- 16. Breathable valve
- 17. Grounding screw
- 18. EPS connector

⚠ Note:
 1. Only three-phase meter supports current direction detection.
 2. Function introduction of communication ports(14) in the follow.

⚠ Note:
 1. This file will be updated from time to time due to product upgrades or other reasons. Unless otherwise agreed, this document is intended as a guide only. All information and suggestions do not constitute an express or implied warranty. The final interpretation of the content is at Growatt.
 2. This document is for quick guidance installation only. For details, please refer to the User Manual.
 3. Machine damage caused by failure to follow the content is not covered by the warranty.

2. Installation

System Overview

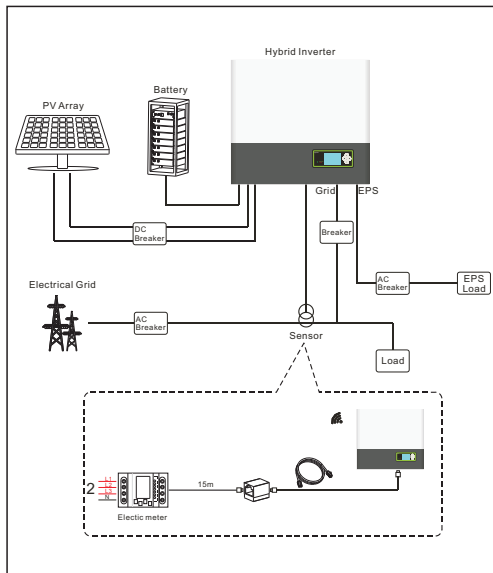

⚠ Note:
 The installation of this hybrid system needs to comprehensively consider the position of the battery and the power collector.

2.1 Installation requirements

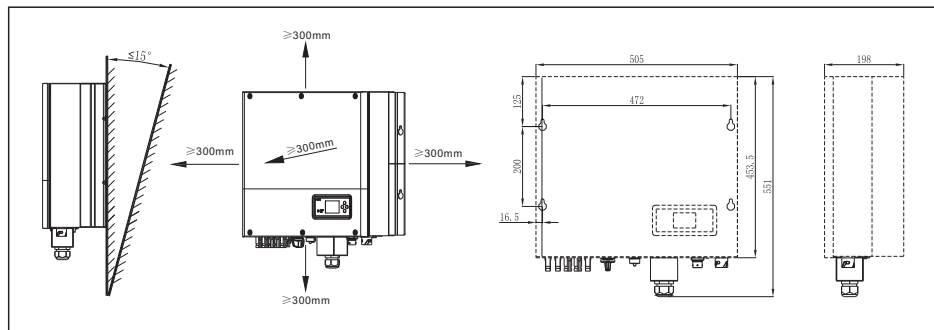

2.2 Wall mounting

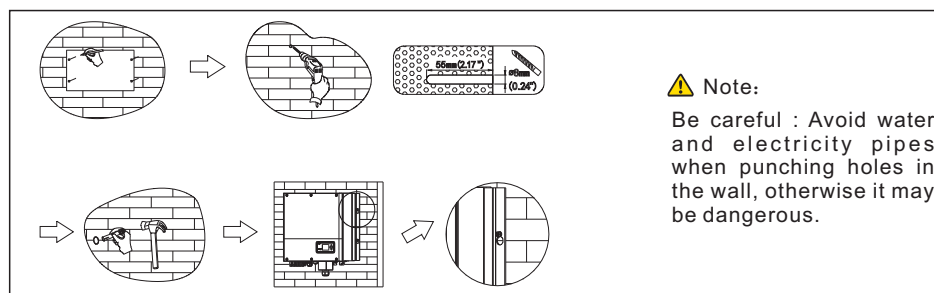

2.3 communication module installation

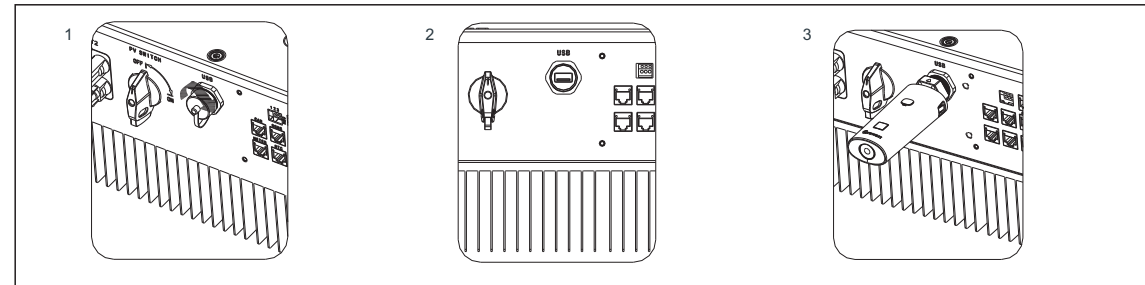

Follow the installation steps:
 1. Remove the USB waterproof cover.
 2. Plug in the communication module.

3. Connecting cables

Please prepare the cable before connecting as follows.

Number	Cable name	Type	Recommend module
1	Grounding wire	Single multi-core yellow-green copper wire	Wire diameter>AWG10
2	AC output wire	Two or three different color multi-core copper wires	Wire diameter>AWG12
3	PV input wire	Photovoltaic dedicated cable (such as PV1-F)	4mm ² - 6mm ²
4	Battery input wire	Red and black multi-core copper	Wire diameter>AWG10
5	Communication wire	CAT5E	/

⚠ Notice:
 1. Lithium battery has its own power line and communication line, so please use them directly.
 2. Hybrid inverter include the basic communication line. So please use them directly.
 3. Please make sure all the switches off before connection. For your safety, please do not operation when power on.

3.1 Grounding

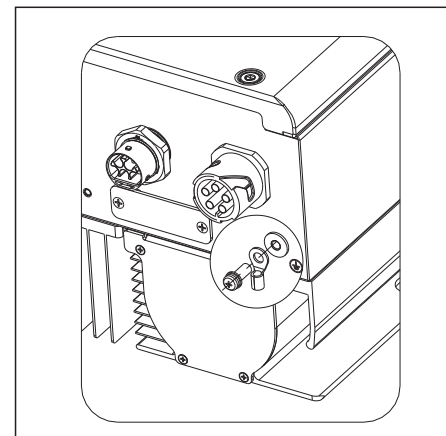

3.2 AC GRID and EPS output connection

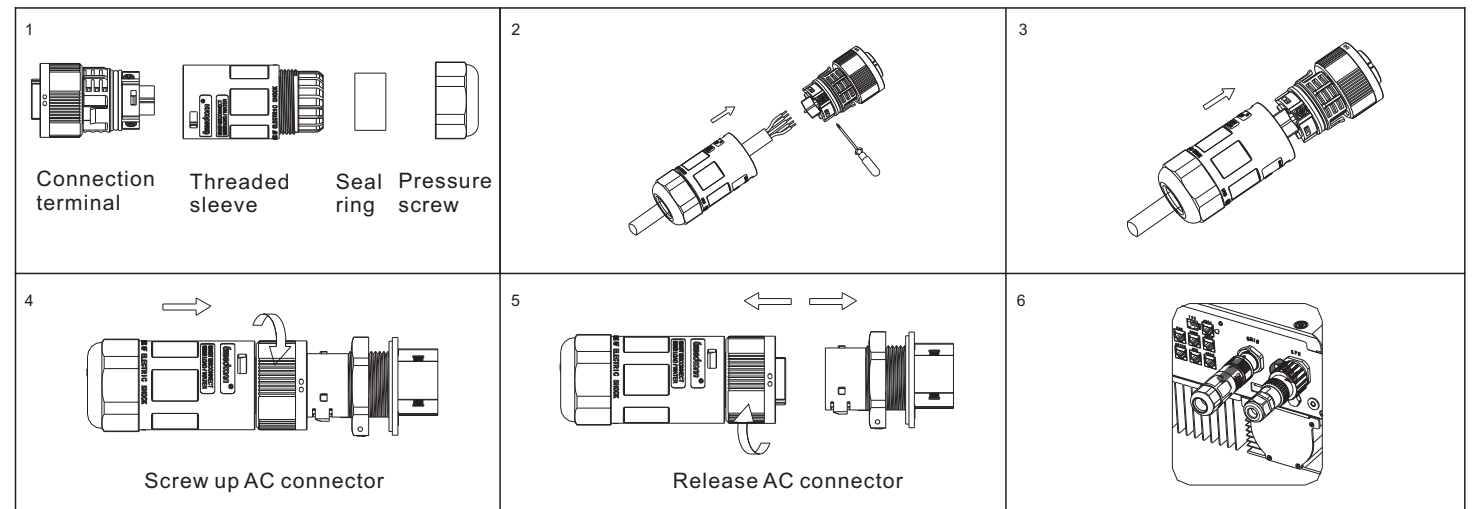
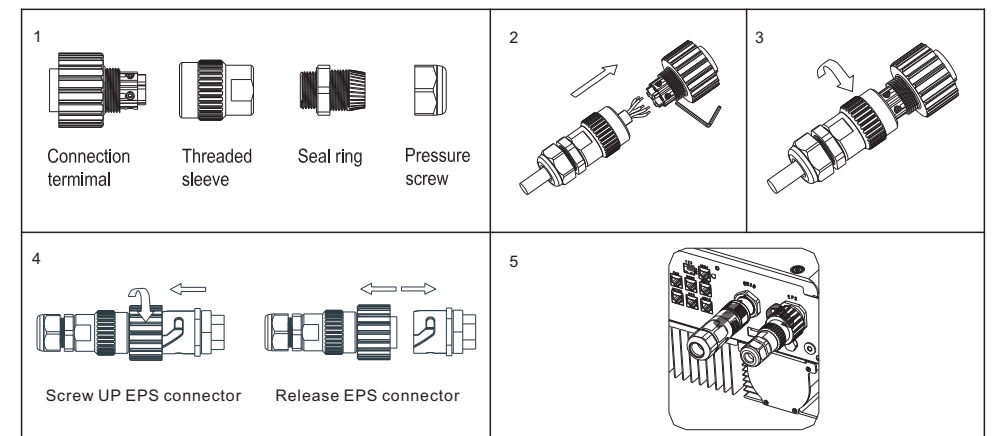

3.3 DC connection

3.3.1 PV and Battery input terminal installation

<p>1</p> <p>Positive metal terminal 8-10 mm Negative metal terminal 8-10 mm</p>	<p>2</p> <p>Please make sure cable can't put out from terminal after pressing.</p>	<p>3</p> <p>Positive metal terminal Negative metal terminal Pull the PV or Battery cable make sure there is no loosen or shaking.</p>
<p>4</p> <p>Lock nut to ensure fastening.</p>	<p>5</p> <p>Make sure the cable polarity is correct.</p>	

3.3.2 Plug in PV terminal

<p>1</p> <p>PV+ click PV-</p>	<p>2</p> <p>click</p> <p>Notes: 1. Please make sure the PV input voltage/current not beyond the specification before plug in. 2. When installing the PV terminal, pay attention to the distinction between the positive and negative terminals and the one-to-one correspondence between the terminals and hybrid inverter. 3. When the terminal is docked, there is a click sound. After the terminal is docked, gently pull the PV cable to observe whether the terminal is shaking or not.</p>
---------------------------------------	--

3.3.3 Plug in Battery terminal

<p>1</p> <p>Blue terminal BAT+ click BAT-</p>	<p>2</p> <p>click</p> <p>Notes: 1. Turn off the battery cabinet switch and disconnect the CAN communication cable before inserting. Make sure that the battery input voltage/current does not exceed the specifications. 2. When installing the battery terminal, pay attention to the distinction between the positive and negative terminals and the one-to-one correspondence between the terminals and hybrid inverter. 3. When the terminal is docked, there is a click sound. After the terminal is docked, gently pull the battery cable to observe whether the terminal is shaking or not.</p>
---	---

3.3.4 Communication cables installation

<p>1</p> <p>RJ45 terminal Pressure screw Threaded sleeve RJ45 terminal Communication line Seal ring Waterproof cover</p>	<p>2</p>	<p>3</p> <p>DRY CONTACT NTC DRMS METER1 CAN RS485/METER2</p>	<p>When all the communication lines are installed, push the waterproof cover into the bottom, lock the screws fixed to the frame, and finally lock the waterproof cap.</p>
<p>4</p>	<p>5</p>	<p>6</p>	

4. Post-installation check

Number	Acceptance Criteria	Number	Acceptance Criteria
1	Hybrid inverter is installed correctly and firmly	2	ShineWiFi-X or Shinelink or GPRS is installed correctly and firmly.
3	Cable wiring is reasonable, meets the requirements, no broken skin, etc.	4	The ground wire confirms the connection and is reliable.
5	All switches off	6	All wires are correct and securely connected.
7	Cable tie port trimming, no sharp corners, etc.	8	All exposed terminals are well protected, no vacant ports.
9	Pay attention to packing all the residual materials.		

5. On off hybrid inverter

Notes:
 Before power on, please make sure all of the voltage and current are in the range of specification of hybrid inverter. Otherwise it will be damage to hybrid inverter.
 Follow are the steps of turn on actions:
 1. Turn on the switch between Grid and hybrid inverter.
 2. Turn on battery and the switch between battery and hybrid inverter.
 3. Turn on PV switch.
 4. Turn on Battery switch.
 5. If need to setup hybrid inverter. Please turn to user manual of hybrid inverter for detail description.
 6. The shutdown steps are opposite to the above order.
 7. The hybrid has an installation diagnosis function, please run "DiagnoseFun" after the installation is completed.

6. Status of hybrid inverter

Customer can read more information by push button. Follow are the instruction of button and LED.

Mark	Description	Explanation	
	Push-button	Operation of display screen and set system	
	Status symbol of SPH	Green light on	SPH run normally
		Red light on	Fault state
		Green light blinking	Alarm state
		Red light blinking	Software updating

7. Definition of RJ45 Port Pin

No.	CAN	METER	COM	DRMS	NTC	485-1/485-2	485-3
1	/	RS485B	DRY+	DRM1/5	GND	RS485B	RS485B
2	/	GND	/	DRM2/6	GND	GND	GND
3	/	/	DRY-	DRM3/7	GND	/	/
4	CANH	/	/	DRM4/8	GND	RS485B	/
5	CANL	RS485A	/	REF	NTC	RS485A	RS485A
6	GND	/	/	COM	NTC	/	/
7	/	/	/	/	NTC	RS485A	/
8	WAKEUP	/	/	/	/	RS485B	/

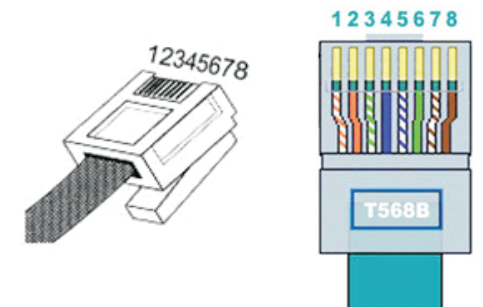

8. Service and contact

Shenzhen Growatt New Energy Co., Ltd
 4-13/F, Building A, Sino-German(Europe) Industrial Park,
 Hangcheng Ave, Bao'an District, Shenzhen, China

T +86 0755 2747 1942
 E service@ginverter.com
 W www.ginverter.com



Download Manual



Growatt New Energy