



USER MANUAL

ESS Inverter

HISTORY

VERSION	ISSUED	COMMENTS
1.0	29-Oct.-21	First release
1.1	10-Dec.-21	Cover, bookmark, external view, communication connection, LED, technical specification etc. section details updated

Preface

About This Manual

This manual describes the installation, connection, the use of SETouch, commissioning and maintenance etc. of ESS inverter. Please first read the manual and related documents carefully before using the product and store it in a place where installation, operation and maintenance personnel can access it at any time. The illustration in this user manual is for reference only. This user manual is subject to change without prior notice. (Specific please in kind prevail.)

Target Group

ESS inverters must be installed by professional electrical engineers who have obtained relevant qualifications.





Scope

This manual is applicable to following inverters:

- SE 4K6HB-60
- SE 4K6HB-120
- SE 5KHB-120
- SE 5KHB-60
- SE 6KHB-120
- SE 6KHB-60
- SE 4K6AC
- SE 5KAC
- SE 6KAC

Conventions

The following safety instructions and general information are used within this user manual.

 DANGER	Indicates an imminently hazardous situation which, if not correctly followed, will result in serious injury or death.
 WARNING	Indicates a potentially hazardous situation which, if not correctly followed, will result in serious injury or death.
 CAUTION	Indicates a potentially hazardous situation which, if not correctly followed, could result in moderate or minor injury.
 NOTICE	Indicates a potentially hazardous situation which, if not correctly followed, could result in equipment failure to run, or property damage.
 NOTE	Call attention to important information, best practices and tips: supplement additional safety instructions for your better use of the SE series hybrid inverter to reduce the waste of you resource.

CONTENTS

Preface

- About This Manual
- Target Group
- Scope
- Conventions

1. Safety

- 1.1 Symbols Used
- 1.2 Safety Precaution

2. Product Introduction

- 2.1 Overview
- 2.2 Product Appearance
- 2.3 Model Definition

3. Installation

- 3.1 Packing List
- 3.2 Selecting the Mounting Location
- 3.3 Mounting

4. Electrical Connection

- 4.1 Grounding
- 4.2 Grid/UPS Connection
- 4.3 Battery Connection
- 4.4 PV Connection
- 4.5 Meter/CT Connection
- 4.6 Communication Connection

5. System Operation

- 5.1 Inverter Working Mode
- 5.2 Startup/Shutdown the System

6. Commissioning

- 6.1 Inspection
- 6.2 Commissioning Procedure

7. User Interface

- 7.1 LED
- 7.2 App Setting Guide

8. Maintenance

- 8.1 Routine Maintenance
- 8.2 Inverter Troubleshooting
- 8.3 Removing the Inverter

9. Technical Specifications









1. Safety

Before using the inverter, please read all instructions and cautionary markings on the unit and manual. Put the instructions where you can take them easily.

The SE series hybrid inverter of ours strictly conforms to related safety rules in design and test. Local safety regulations shall be followed during installation, operation and maintenance.

Incorrect operation work may cause injury or death to the operator or a third party and damage to the inverter and other properties belonging to the operator or a third party.

1.1 Symbols Used

Safety Symbol	Description
	Danger of high voltage and electric shock! Only qualified personnel may perform work on the inverter.
	Danger of high voltage. Residual voltage in the inverter need 5 mins to discharge, wait 5 mins before operation.
	Danger of hot surface
	Fire danger
	Environmental Protection Use Period
	Refer to the operating instructions
	Product should not be disposed as household waste.
	Grounding terminal

1.2 Safety Precaution

- Installation, maintenance and connection of inverters must be performed by qualified personnel, in compliance with local electrical standards, wiring rules and requirements of local power authorities and/or companies (for example: AS 4777 and AS/NZS 3000 IN Australia).
- To avoid electric shock, DC input and AC output of the inverter must be terminated at least 5 minutes before performing any installation or maintenance.
- The temperature of some parts of the inverter may exceed 60°C during operation. To avoid being burnt, do not touch the inverter during before touching it.
- Ensure children are kept away from inverters.
- Don't open the front cover of the inverter. Apart from performing work at the wiring terminal (as instructed in this manual), touching or changing components without authorization may cause injury to people, damage to inverters and annulment of the warranty.
- Static electricity may damage electronic components. Appropriate method must be adopted to prevent such damage to the inverter; otherwise the inverter may be damaged and the warranty annulled.
- Ensure the output voltage of the proposed PV array is lower than the maximum rated input voltage of the inverter; otherwise the inverter may be damaged and the warranty annulled.
- When exposed to sunlight, the PV array generates dangerous high DC voltage. Please operate according to our instructions, or it will result in danger to life.
- PV modules should have an IEC61730 class A rating.
- If the equipment is used in a manner not specified by the manufacturer, the protection provided by the equipment may be impaired.
- Completely isolate the inverter before maintaining. Completely isolate the inverter should: Switch off the DC switch, disconnect the PV terminal, disconnect the battery terminal, and disconnect the AC terminal.
- Prohibit to insert or pull the AC and DC terminals when the inverter is running.
- In Australia, the inverter internal switching does not maintain the neutral integrity, neutral integrity must be addressed by external connection arrangements.
- In Australia, the output of backup side in switchbox should be labeled main switch UPS supply, the output of normal load side in switchbox should be labeled mains witch inverter supply
- Don't connect SE series in the following ways:
 EPS Port should not be connected to grid;
 EPS Port should not be connected in parallel;
 The single PV panel string should not be connected to two or more inverters.

2. Product Introduction

2.1 Overview

Hybrid Inverter

The SE series hybrid inverters are high-quality inverter which can convert solar energy to AC energy and store energy into battery.

The inverter can be used to optimize self consumption, store in the battery for future use or feed into public grid. Work mode depends on PV energy and user's preference. It can provide power for emergency use during the grid lost by using the energy from battery and inverter (generated from PV).

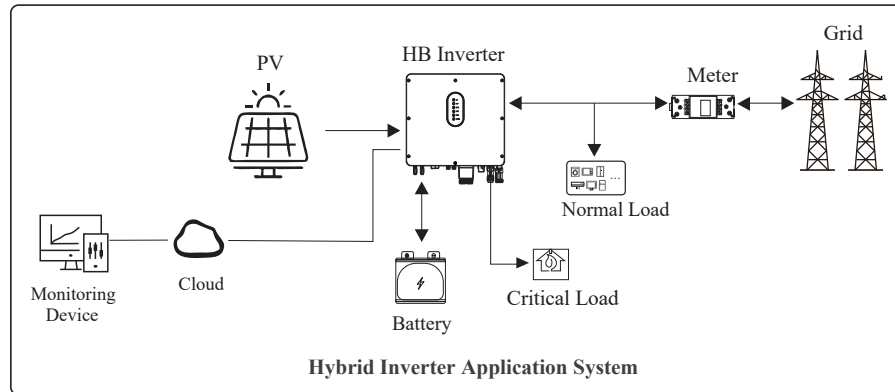

AC Couple Inverter

The SE series AC couple inverters are high-quality inverter which can store energy into battery. The inverter can be used to optimize self consumption, store in the battery for future use or feed into public grid. Work mode depends on the battery and user's preference. It can provide power for emergency use during the grid lost by using the energy from battery.

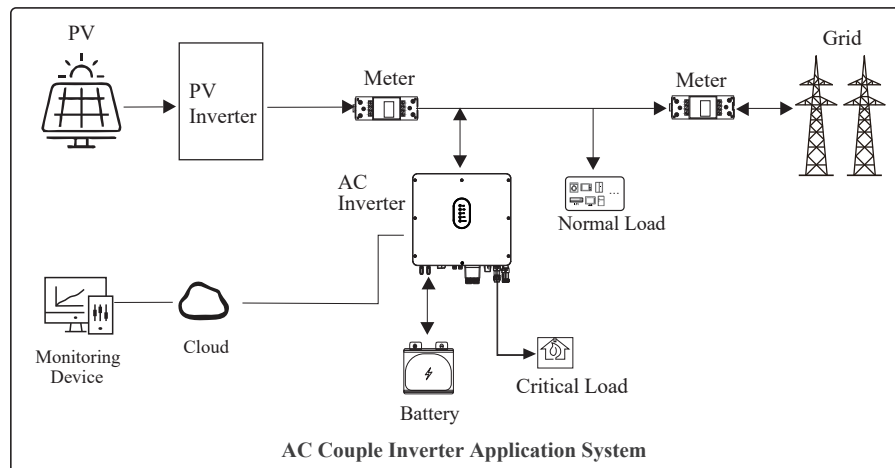

2.2 Product Appearance

2.2.1 Hybrid Inverter

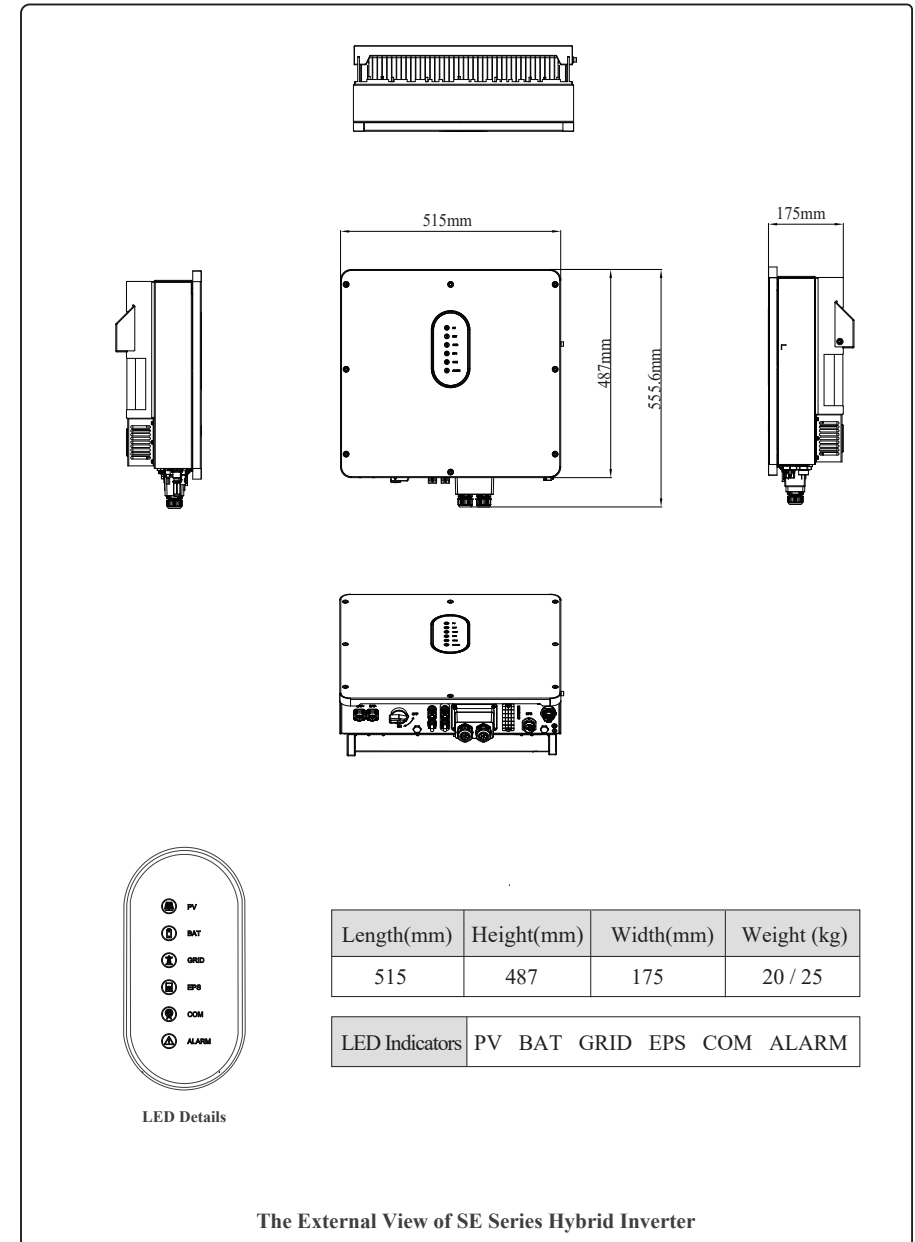

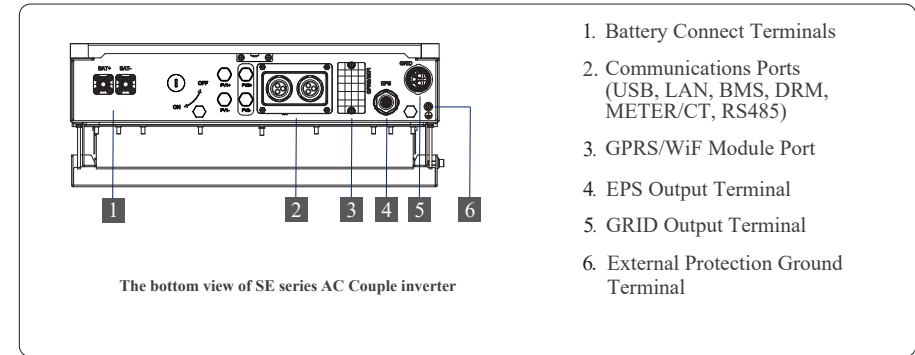
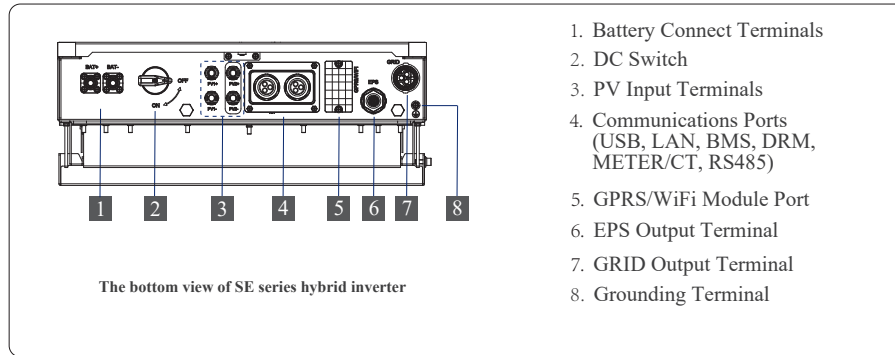

2.2.2 AC Couple Inverter

Note: The appearances of SE series hybrid inverter and SE series AC couple inverter are presented in detail in this section. The following chapters are only illustrated by SE series hybrid inverter.

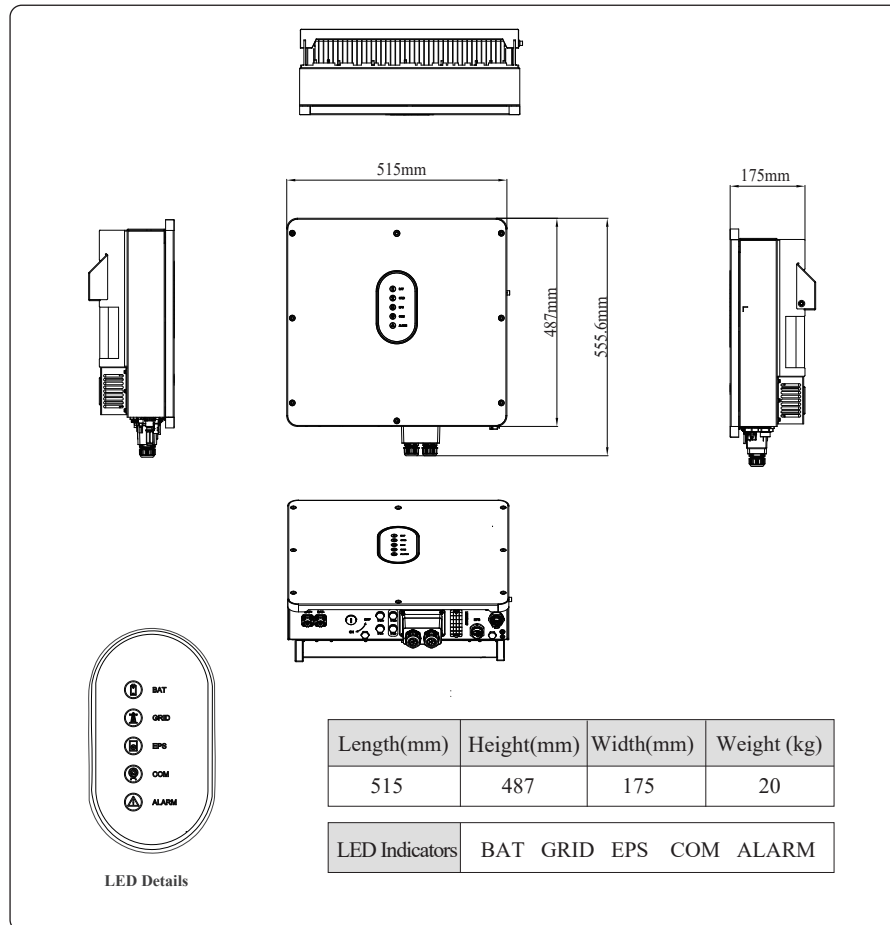

2.3 Model Definition

The letters in the product model have the specific informations.
(Take SE 5KHB-60/SE 4K6AC as example.)

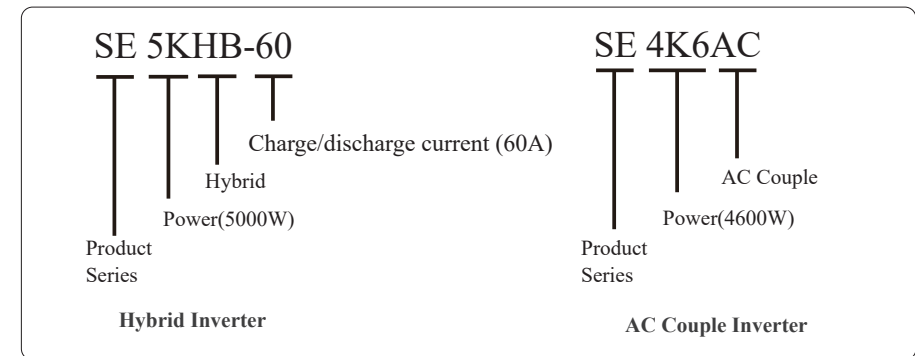

3. Installation

3.1 Paking List

After unpacking, please check the following packing list carefully for any damage or missing parts. If any damage or missing parts occurs, contact the supplier for help.

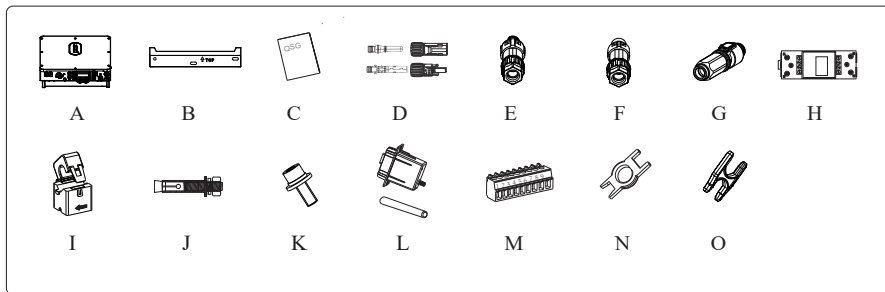

Number	Quantity	Description
A	1	Inverter
B	1	Mounting bracket
C	1	QSG
D	2/2	PV terminal connector group (PV+/PV-) ; N/A for AC Couple
E	1	EPS connector
F	1	Grid connector
G	2	Battery connector
H	1	Meter (Optional)
I	1	CT
J	3	M12 Expansion screws
K	1	M6 Security screw
L	1	GPRS/WiFi module (Optional)
M	1	9-Pins terminal
N	1	Removel tool for PV connector
O	1	Removel tool for Grid/EPS connector

3.2 Selecting the Mounting Location

3.2.1 Installation Environment Requirements

- The storage inverter protection class is IP65 and can be mounted indoors or outdoors.
- The mounting location must be inaccessible to unrelated personnel since the enclosure and heat sinks are extremely hot during operation.
- Do not install the storage inverter in areas containing highly flammable materials or gases.
- To ensure optimum operation and long service life, the ambient temperature must be below 50°C.
- The storage inverter must be mounted in a well ventilated environment to ensure good heat dissipation.
- To ensure long service life, the storage inverter must not be exposed to direct solar irradiation, rain, or snow. It is recommended that the inverter be mounted in a sheltered place.
- The carrier where the inverter is mounted must be fire-proof. Do not mount the inverter on flammable building materials.
- Do not install the inverter in a rest area since it will cause noise during operation.
- The installation height should be reasonable and make sure it is easy to operate and view the display.
- Product label and warning symbols shall be clear to read after installation.
- Please avoid direct sunlight, rain exposure, snow lay up install.

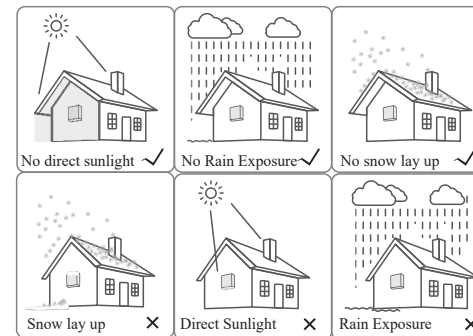

3.2.2 Mounting Requirements

Mount the inverter vertically or tilted backward by max 15°. The device can not be installed with a wrong mode and the connection area must point downward.

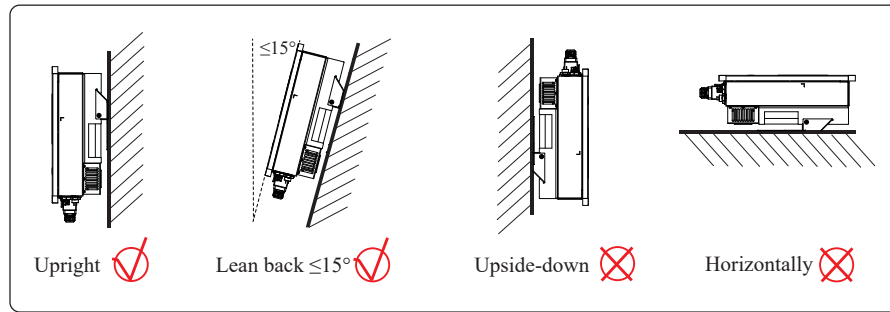

3.2.3 Installation Space Requirements

To ensure the inverter normally and easy to operate, there are requirements on available spaces of the inverter, e.g. to keep enough clearance. Refer to the following figures.

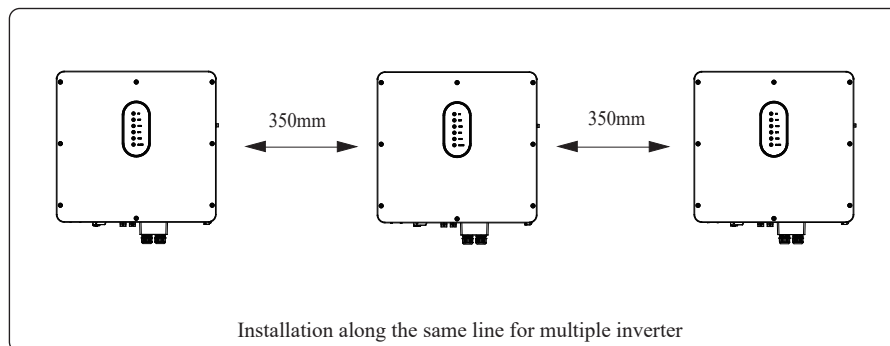
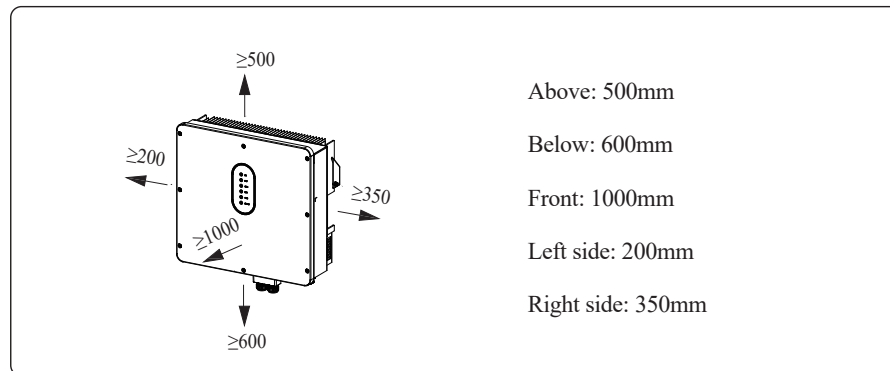

3.3 Mounting

Before mounting the inverter, you have to prepare expansion bolts (specification: M12*80; Quantity: 3).

Step 1. Install the mounting bracket

1. Use a level ruler to mark the position of the 3 holes on the wall. Refer to Figure a. And drill 3 holes, 16mm in diameter and 55mm in deep. Refer to Figure b.
2. Knock the expansion screw kit into the hole together with a hammer. Refer to Figure c.
Note: Do not remove the nut unit in Figure c.
3. After tightening 2-3 buckles, the expansion bolts are tight and not loose, and then unscrew the bolts, spring washer, gasket. Refer to Figure c.
4. Install and fix the mounting bracket on the wall. Refer to Figure d.

Step 2. Install the inverter on the mounting bracket. Then lock the inverter using the security screw. Refer to Figure d.

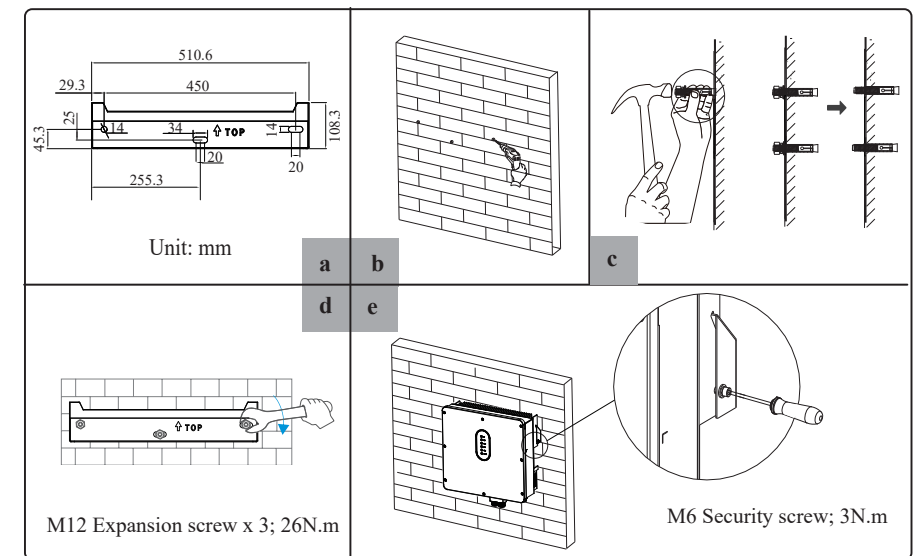

⚠ DANGER Before frilling the hole on the wall, ensure no damage on the electric wire and/or water pipe inside the wall.

⚠ CAUTION To prevent potential damages and injuries from inverter falling down, please hang the inverter on the bracket, do not loosen grip unless confirm the inverter is well mounted.

4. Electrical Connection

This chapter shows the details connection of ESS inverter. And PV connection is N/A for SE series AC couple inverters. The following illustration only uses the SE series hybrid inverters as an example.

ESS inverter system connection diagram:

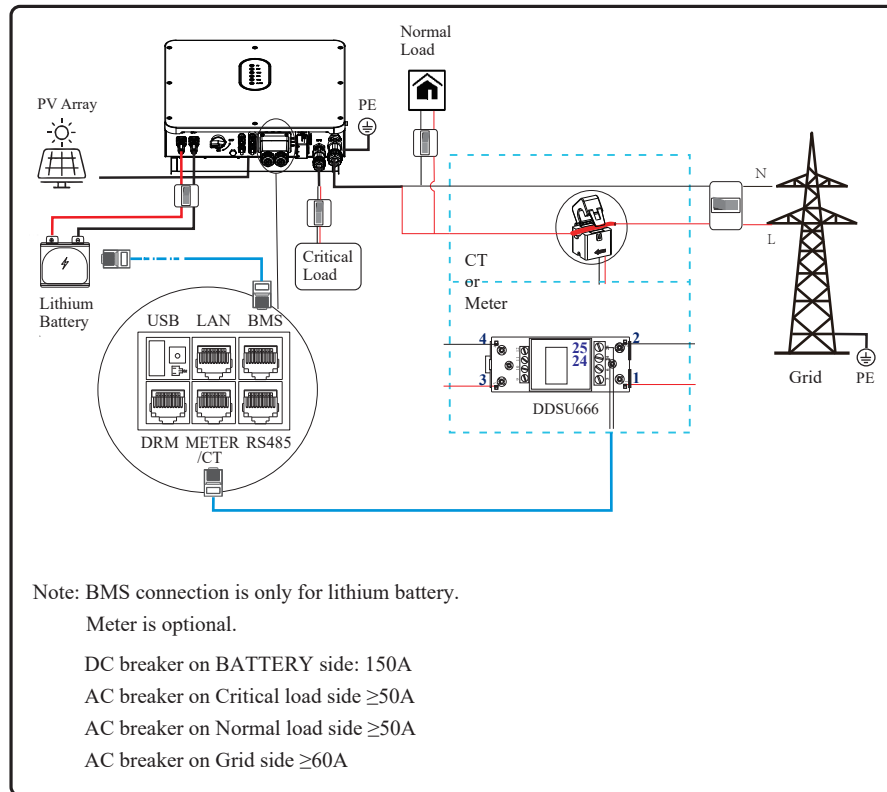

⚠ DANGER Ensure that inverter and all cables to be installed are completely powered off during whole installation and connection. Otherwise, fatal injury can occur due to the high voltage caused from AC and DC cables.

4.1 Grounding

A protective earth (PE) terminal is equipped at the side of the inverter. Please be sure to connect this PE terminal to the PE bar for reliable grounding. AWG 10 or 12 yellow green lines are recommended.

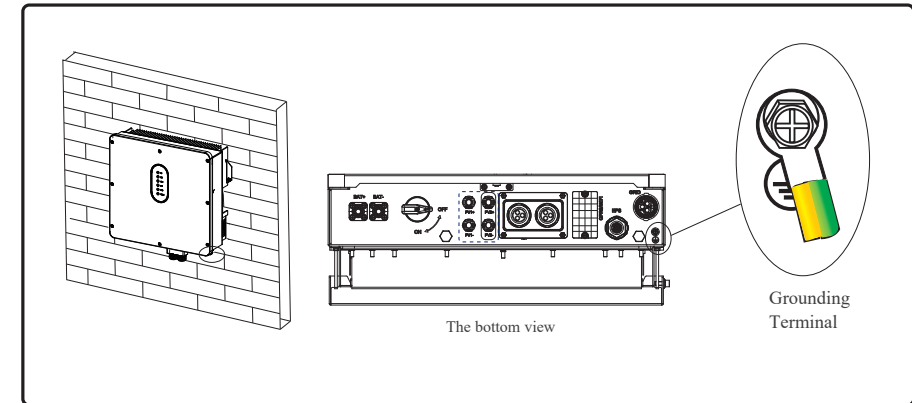

- ⚠ WARNING** The inverter must be grounded; otherwise, there may be electric shock risk.
- ⚠ CAUTION** If the positive pole or negative pole of the PV array is required to be grounded, then the inverter output (to ACgrid) must be isolated by transformer in accordance with IEC62109-1, -2 standards.

4.2 Grid/EPS Connection

Grid/EPS connection please refer to below.

Step 1: Assemble the AC connector.

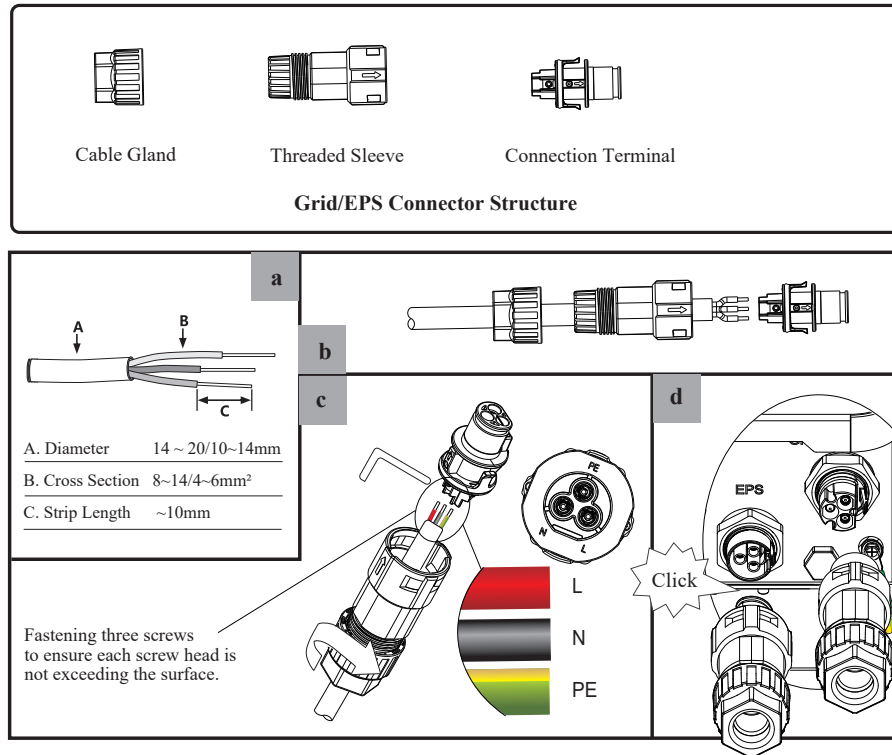

Step 2: Connect the AC connector.

An AC breaker should be installed between inverter and the grid/EPS.

- Before connecting the AC cable from inverter to AC breaker, you should confirm the AC breaker is working normally. Turn off the AC breaker and keep it open.
- Connect the PE conductor to grounding electrode, and connect the N and L conductors to AC breaker.
- Connect the AC breakers to the grid/EPS grid.

	<p>NOTICE</p> <ul style="list-style-type: none"> Multiple inverters are not allowed to share a circuit breaker. Load is not allowed to connect between the inverter and the AC breaker.
--	--

To ensure that the inverter can be safely and reliably disconnected from the grid, a AC breaker (≥50A) should be installed only for inverter grid/EPS port..

4.3 Battery Connection

SE Series hybrid inverter now only supports the lithium / lead-acid battery. The recommended lithium battery brands are as follows: PYLON LPF, Aoboet LPF, Dyness LPF, UZENERGY L051100-A.

This part in this manual only describe the battery connection on inverter side. If you need more detailed connection information about the battery side, please refer to the manual of the battery you using.

Before connecting to battery, please install a separate DC breaker (150A; not equipped) between inverter and battery. This ensure the inverter can be security disconnected during maintenance.

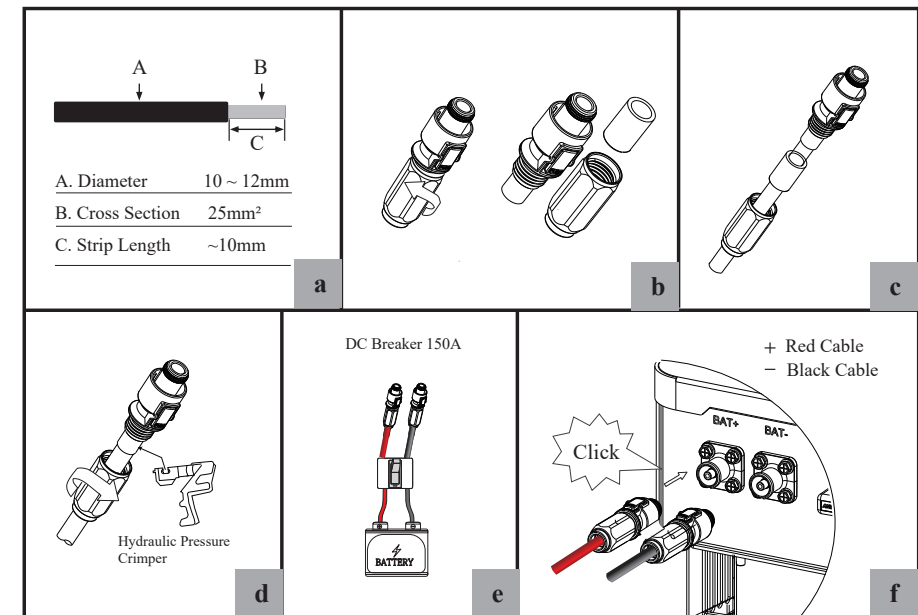

<p>WARNING</p>	<ul style="list-style-type: none"> Polarity reverse will damage the inverter! Be careful of electric shock and chemical hazards! To reduce risk of injury, please use the suitable recommended cable size.
-----------------------	---

Battery Communication Connection

If the battery type is lithium battery which need communication between the inverter and battery management system(BMS), the connection must be installed.

Please refer to section 4.6.2 for details.

4.4 PV Connection (N/A for AC Couple Inverter)

PV connection please refer to below.

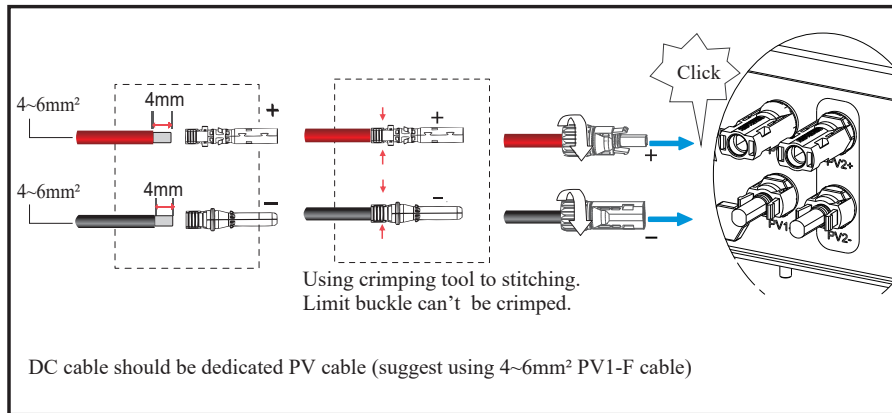

 NOTICE	<ul style="list-style-type: none"> • Before connection the PV panels, make sure the plug connector have the correct polarity. Incorrect polarity could permanently damage the inverter. • PV array shouldn't be connected to the grounding conductor. • The minimum insulation resistance to ground of the PV panels must exceed 18.33kΩ, there is a risk of shock hazard if the requirement of minimum resistance is not met.
---	---

4.5 Meter/CT Connection

You can monitor usage with a meter or a CT. The meter and CT can't be installed at the same time. The meter is optional.

4.5.1 Meter Connection

SE series inverter only supports the meter: CHNT-DDSU666 meter.

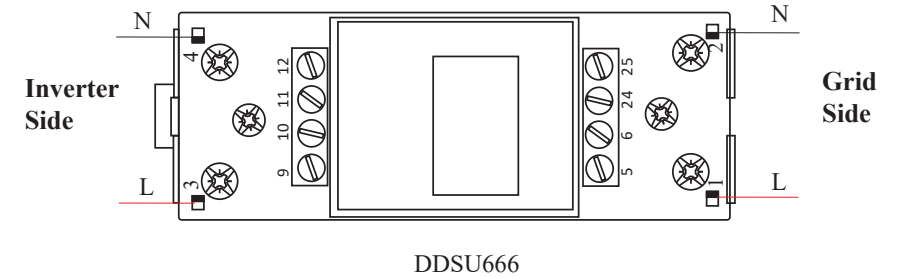

Before connecting to Grid, please install a separate AC breaker (≥60A; not equipped) between meter and Grid. This ensure the inverter can be security disconnected during maintenance.

The connection diagram of power cable of meter is as shown in the figure below:

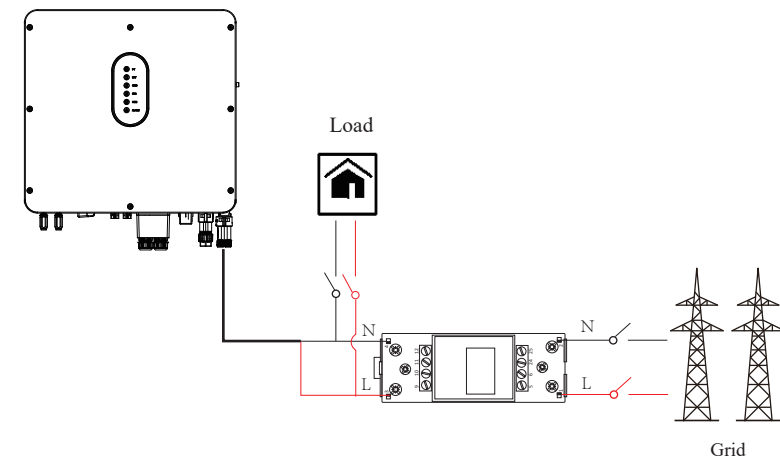

Please refer to the meter instruction manual for details.

4.5.2 CT Connection

Before connecting to Grid, please install a separate AC breaker ($\geq 60A$; not equipped) between CT and Grid. This ensure the inverter can be security disconnected during maintenance.

The connection diagram of power cable of CT is as shown in the figure below:

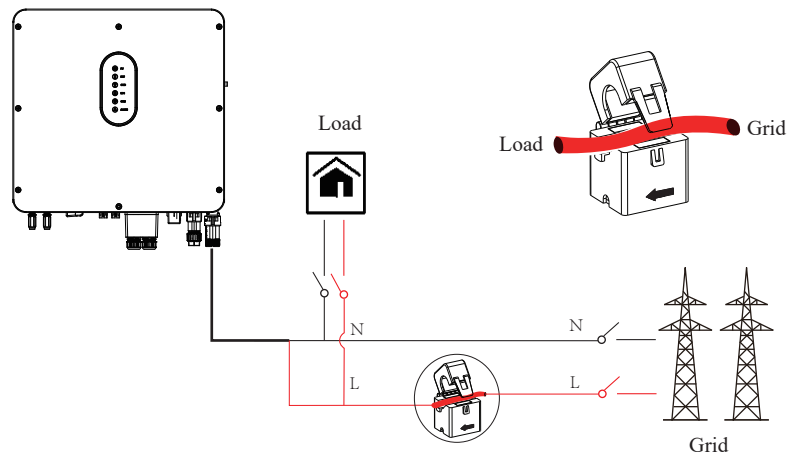

Please attention to the Current interchanger (CT) connection. The arrow on the CT indicates the current flow from grid to inverter. And lead the live line through the detection hole of CT.

 NOTE	The current direction from grid to inverter is defined as positive and current direction from inverter to grid is defined as negative.
---	--

4.6 Communication Connection

There are communication interfaces in the communication port on the bottom of the inverter as show below :

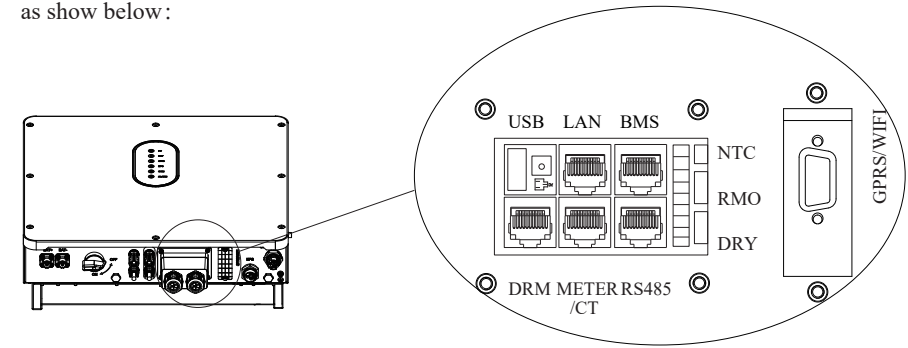

Interface	Descriptions	
USB	For fast firmware upgrade.	
LAN	For ethernet communication.	
BMS	Lithium battery Communication Interface	
DRM	Demand response mode for Australia application	
METER/CT	For Meter communication or Grid current sense.	
RS485	For RS485 communication.	
9-Pins	NTC	Temperature sensor terminal of lead-acid battery
	RMO	Remote off control
	DRY	DI/DO control
GPRS/WIFI	For GPRS/WIFI communication.	

4.6.1 LAN Connection

Use standard Ethernet cable for ethernet communication.

RJ45 Terminal Configuration of LAN

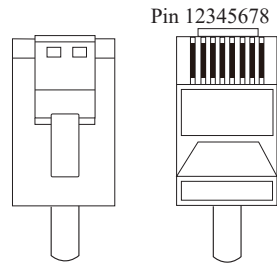

Refer to the following steps:

a Unscrew the waterproof cover and loosen the rubber nut on waterproof cover.

c Insert RJ45 terminals into corresponding ports. Install the seal into the threaded sleeve, fasten the rubber nut and screw the waterproof cover back to inverter firmly with 4 x M4 screws; 1.2N.m.

b Lead the Standard Ethernet cable through the rubber nut, seal and waterproof cover in turn.

Don't cut off any communication cables.

Press the standard Ethernet cable in the seal via the side incisions.

4.6.2 BMS Connection (Only for Lithium Battery)

RJ45 Terminal Configuration of Battery Communication (BMS)

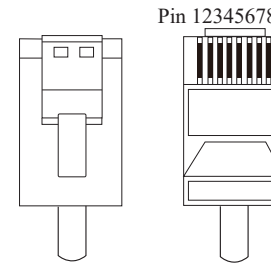

PIN	1	2	3	4
Function Description	RS485_A	RS485_B	GND_S	GND_S
PIN	5	6	7	8
Function Description	GND_S	GND_S	CAN_L	CAN_H

This manual describes the cable sequence of the inverter. For details about the cable sequence of the battery, see the manual of the battery you used.

Refer to the following steps:

a Unscrew the waterproof cover and loosen the rubber nut on waterproof cover.

c Insert RJ45 terminals into corresponding ports. Install the seal into the threaded sleeve, fasten the rubber nut and screw the waterproof cover back to inverter firmly with 4 x M4 screws; 1.2N.m.

b Make the RJ45 terminal according to above function description of each Pin definition. Lead the BMS cable through the rubber nut, seal and waterproof cover in turn.

Don't cut off any communication cables.

Press the BMS cable in the seal via the side incisions.

4.6.3 DRMs Connection

DRMs is a shortened form for “inverter demand response modes”. It is a compulsory requirements for inverters in Australia.

RJ45 Terminal Configuration of DRMs

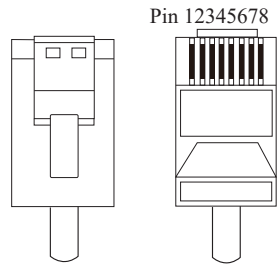

PIN	1	2	3	4
Function Description	DRM1/5	DRM2/6	DRM3/7	DRM4/8
PIN	5	6	7	8
Function Description	REF	DRM 0/COM	NC	NC

Refer to the following steps:

a Unscrew the waterproof cover and loosen the rubber nut on waterproof cover.

c Insert RJ45 terminals into corresponding ports. Install the seal into the threaded sleeve, fasten the rubber nut and screw the waterproof cover back to inverter firmly with 4 x M4 screws; 1.2N.m.

b Make the RJ45 terminal according to above function description of each Pin definition. Lead the BMS cable through the rubber nut, seal and waterproof cover in turn.

! Don't cut off any communication cables.

Press the DRMs cable in the seal via the side incisions.

4.6.4 Meter/CT Connection

RJ45 Terminal Configuration of Meter/CT Communication

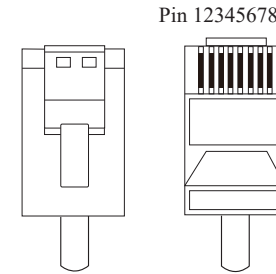

PIN	1	2	3	4	5	6	7	8
Function Description	RS485_A	RS485_B	RS485_A	RS485_B	CT+	CT-	NC	NC

4.6.4.1 Meter Connection

Meter cable connection overview

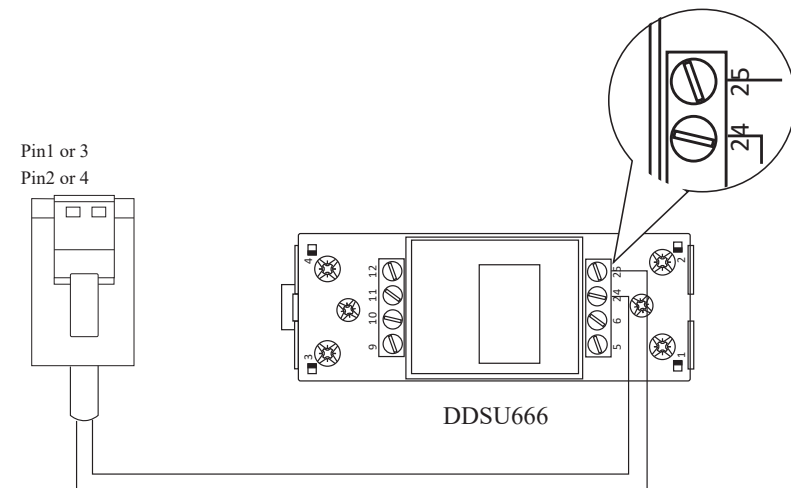

Inverter	Meter
Pin1 or Pin3(RS485_A)	Pin24
Pin2 or Pin4(RS485_B)	Pin25

Connect meter. Refer to the following steps:

a Unscrew the waterproof cover and loosen the rubber nut on waterproof cover.

b Make the RJ45 terminal according to above function description of each Pin definition. Lead the meter communication cable through the rubber nut, seal and waterproof cover in turn.

c Insert RJ45 terminals into corresponding ports. Install the seal into the threaded sleeve, fasten the rubber nut and screw the waterproof cover back to inverter firmly with 4 x M4 screws; 1.2N.m.

Don't cut off any communication cables.

Press the meter cable in the seal via the side incisions.

4.6.4.2 CT Connection

CT cable connection overview

Pin 5,6

CT-
CT+

Inverter	CT
Pin5(CT+)	Red
Pin6(CT-)	Black

Connect CT. Refer to the following steps:

a Unscrew the waterproof cover and loosen the rubber nut on waterproof cover.

b Make the RJ45 terminal according to above function description of each Pin definition. Lead the CT cable through the rubber nut, seal and waterproof cover in turn.

c Insert RJ45 terminals into corresponding ports. Install the seal into the threaded sleeve, fasten the rubber nut and screw the waterproof cover back to inverter firmly with 4 x M4 screws; 1.2N.m.

Don't cut off any communication cables.

Press the CT cable in the seal via the side incisions.

4.6.5 RS485 Connection

RJ45 Terminal Configuration of RS485 Communication

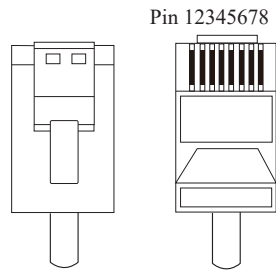

PIN	1	2	3	4
Function Description	GND_S	GND_S	GND_S	GND_S
PIN	5	6	7	8
Function Description	RS485_B	RS485_A	RS485_B	RS485_A

Connect RS485. Refer to the following steps:

a Unscrew the waterproof cover and loosen the rubber nut on waterproof cover.

c Insert RJ45 terminals into corresponding ports. Install the seal into the threaded sleeve, fasten the rubber nut and screw the waterproof cover back to inverter firmly with 4 x M4 screws; 1.2N.m.

b Make the RJ45 terminal according to above function description of each Pin definition. Lead the RS485 cable through the rubber nut, seal and waterproof cover in turn.

RS485 Control Module, Threaded sleeve, RJ45 terminals, Inverter side, Rubber nut, Seal, Waterproof cover.

! Don't cut off any communication cables.

Press the RS485 cable in the seal via the side incisions.

4.6.6 NTC/RMO/DRY Connection(s)

9-Pins Terminal Configuration of Auxiliary Communication

Pin123456789

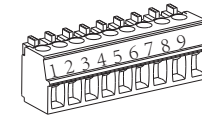

PIN	Function Description
1	NO1 (Normal Open)
2	N1
3	NC1 (Normal Close)
4	NC2 (Normal Close)
5	N2
6	NC2 (Normal Close)
7	REMO OFF
8	GND S (NTC BAT)
9	NTC BAT+

Refer to the following steps:

a Unscrew the waterproof cover and loosen the rubber nut on waterproof cover.

b Make the 9-Pins terminal according to above function description of each Pin definition for the auxiliary port you want to use. Lead the NTC/RMO/DRY cable(s) through the rubber nut, seal and waterproof cover in turn.

NTC/RMO/DRY Control Module(s), Threaded sleeve, 9-Pins terminal, Inverter side, Rubber nut, Seal, Waterproof cover.

! Don't cut off any communication cables.

Press the NTC/RMO/DRY cable(s) in the seal via the side incisions.

Insert its 9-Pins terminal into the corresponding NTC/RMO/DRY port on the ESS inverter. Install the seal into the threaded sleeve, fasten the rubber nut and screw the waterproof cover back to inverter firmly with 4 x M4 screws; 1.2N.m.

4.6.7 GPRS/WiFi Module Connection (Optional)

GPRS/WiFi module connection please refer to below.

Move the port cover. Make sure doesn't fall off naturally. Proper strength to avoid damage to the module. 2 x M4 screws; 0.8N.m. Antenna

5. System Operation

5.1 Inverter Working Mode

The inverter supports several different working modes.

5.1.1 Self Used Mode

Go to the "Hybrid work mode" menu, and select the "Self used mode" working mode.

Under Self Used mode, the priority of PV energy will be Load > Battery > Grid, that means the energy produced by PV gives priority to local loads, excess energy is used for charging the battery, and the remaining energy is fed into the grid.

This is the default mode to increase self-consumption rate. There are several situations of Self used working mode based on PV energy.

a) Wealthy PV Energy

When PV energy is wealthy, the PV energy will first consumed by loads, the excess energy will be used to charge the battery. then the remaining energy will be fed into the grid.

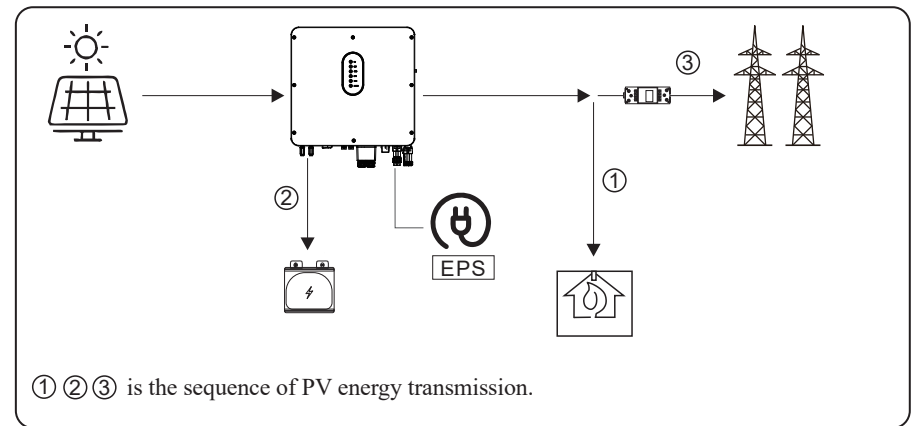

b) Limited PV power

When the PV energy is not enough to cover all the loads, all the PV energy will be used for load, and the insufficient part will be supported by battery. Then still insufficient parts will be supported by grid.

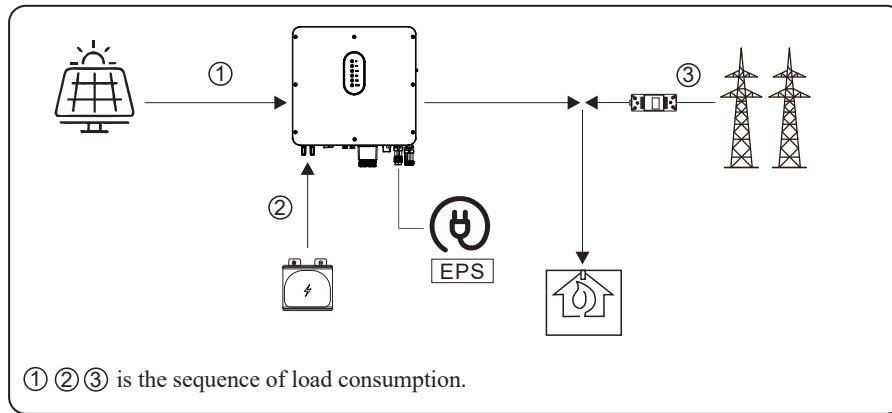

a) Wealthy PV Energy

When PV energy is wealthy, the PV energy will be first consumed by loads, if there is excess PV power, then the excessive power will be fed into grid. If there is still PV energy rested after load consuming and grid feeding, then the rested PV power will be used to charge the battery.

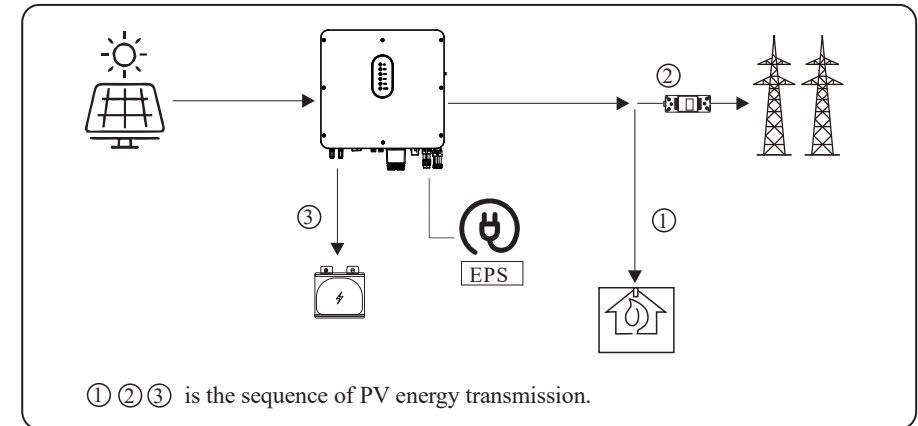

c) No PV Input

The inverter will first discharge the battery energy for home load consuming when no PV input(such as in the evening or some cloudy or rainy days). If the demand is not met then will consume the grid energy.

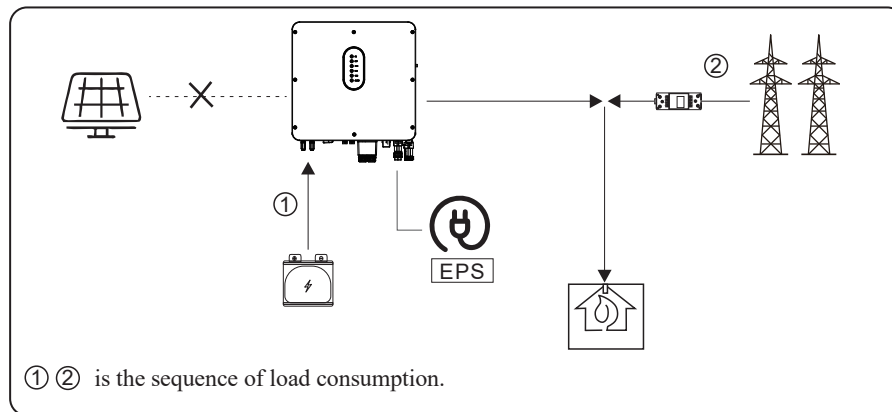

b) Limited PV Energy

When PV energy is limited and can not meet the feed-in grid power, the battery will discharge to meet it.

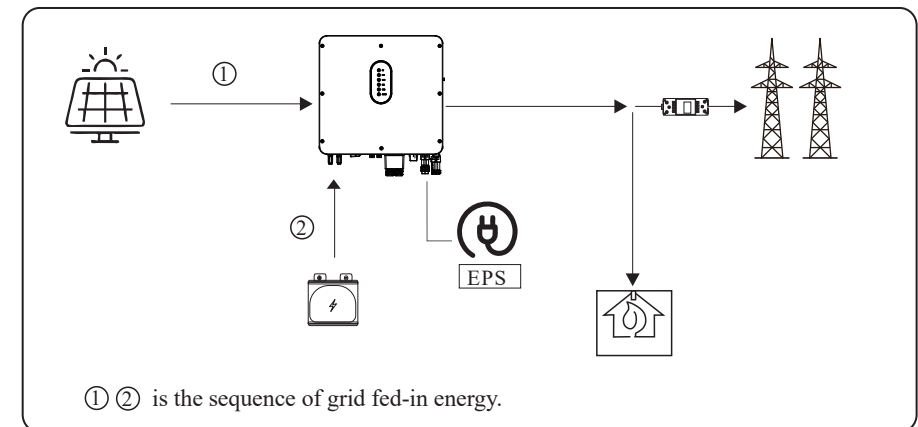

5.1.2 Feed-in Priority Mode

Go to the "Hybrid work mode" menu, and select the "Feed-in priority mode" working mode. Under this mode, the priority of PV energy will be Load > Grid > Battery, that means the energy produced by PV gives priority to local loads, excess energy is fed into the grid, and the remaining energy is used for charging the battery.

c) No PV Input

The inverter will first discharge the battery energy for home load consuming when no PV input(such as in the evening or some cloudy or rainy days). If the demand is not met then will consume the grid energy.

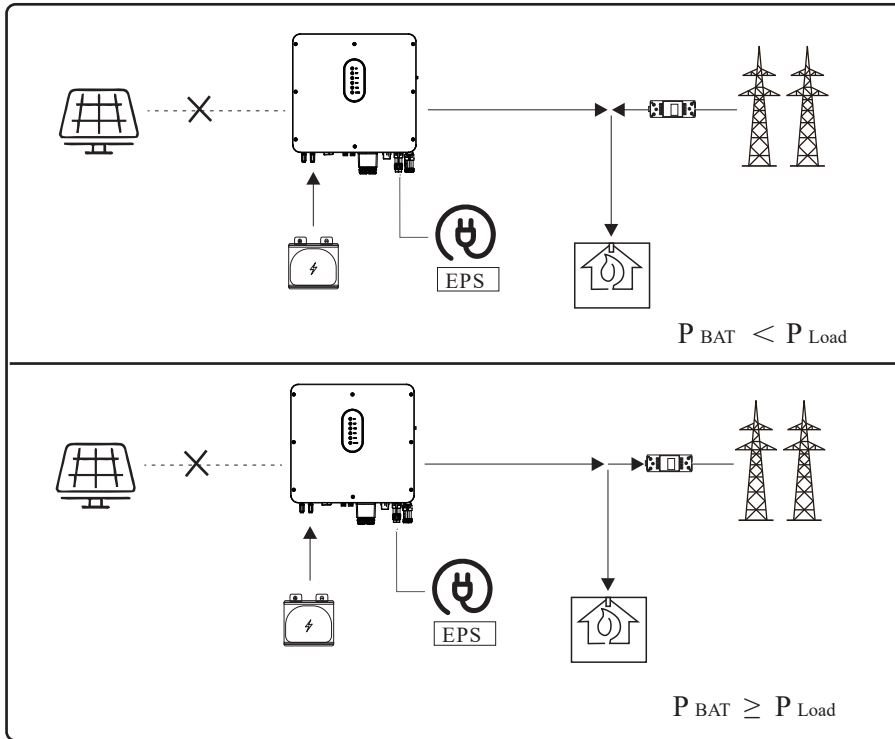

5.1.3 Time-Based Control Mode

Go to the "Hybrid work mode" menu, and select the "Time-based Control" working mode. Under this mode, you can control the charging and discharging of the inverter. You can set the following parameters based on your requirements:

- Charge and discharge frequency: one time or daily
- Charging start time: 0 to 24 hours
- Charging end time: 0 to 24 hours
- Discharge start time: 0 to 24 hours
- Discharge end time: 0 to 24 hours

You can also choose whether to allow the grid to charge the battery, which is prohibited by default. If the user enable the "Grid charge function" , the "Maximum grid charger power" and "Capacity of grid charger end" can be set. When the battery capacity reaches the set value of "Capacity of grid charger end", the grid will stop charging the battery.

5.1.4 Back-up Mode

Go to the "Hybrid work mode" menu, and select the "Back-up mode" working mode.

Under this mode, the priority of PV energy will be Battery > Load > Grid.

This mode aims at charging the battery quickly, and at the same time, you can choose whether to allow AC to charge the battery.

Forbid AC charging

In this mode, the battery can be charged only with PV power, and the charging power varies with PV power.

a) Wealthy PV power

When PV energy is wealthy, PV charges the battery first, then meets the load, and the rest is fed into the grid.

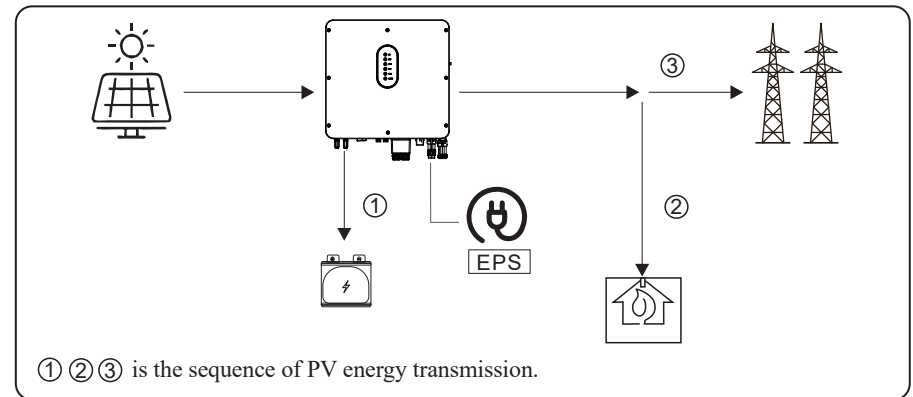

b) Limited PV power

When PV energy is limited, PV gives priority to charging the battery, and the grid directly meet the load demand.

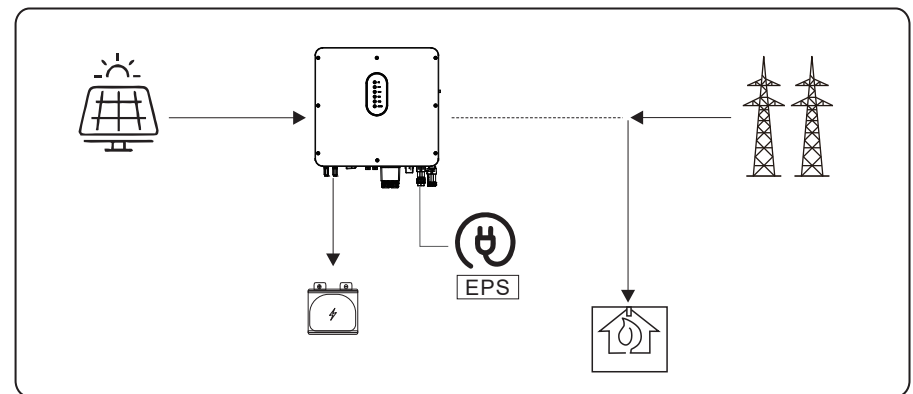

Allow AC charging

In this situation, the battery can be charged both with PV and AC.

a) Wealthy PV power

When PV energy is wealthy, PV charges the battery first, then meets the load, and the rest is fed into the grid.

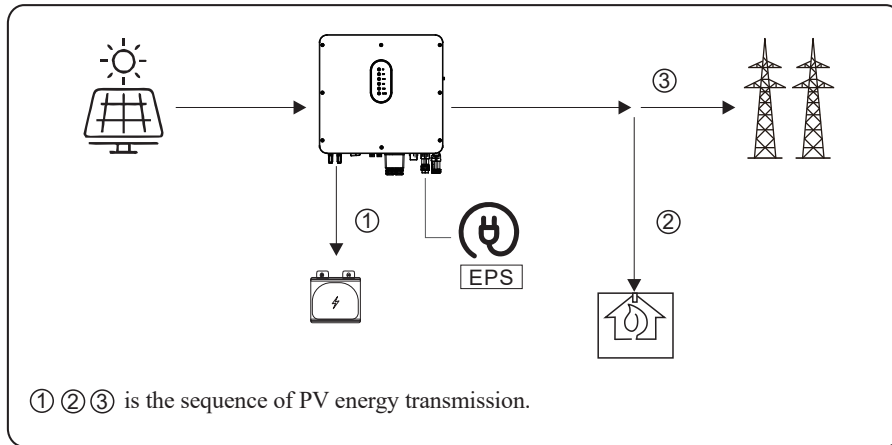

b) Limited PV power

When the PV energy is not enough to charge the battery, the grid energy will charge the battery as supplement. Meanwhile, the grid energy is consumed by loads.

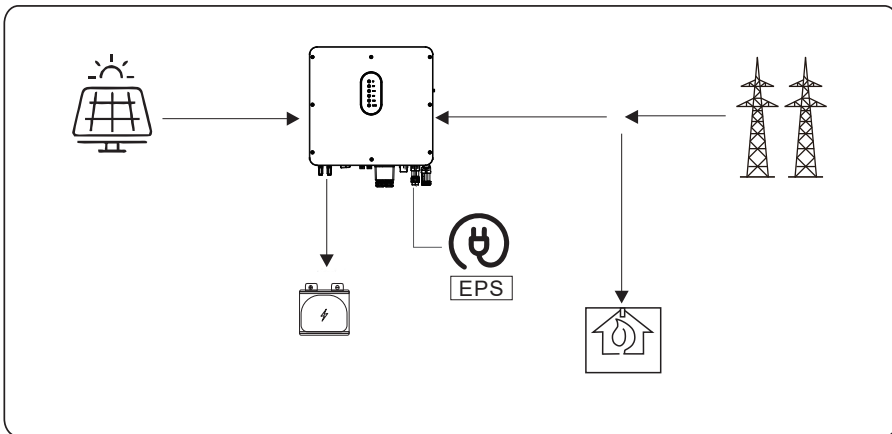

5.1.5 Off Grid Mode

When the power grid is cut off, the system automatically switches to Off Grid mode.

Under off-grid mode, only EPS loads are supplied to ensure that important loads continue to work without power failure.

Under the this mode, the inverter can't work without the battery.

a) Wealthy PV power

When PV energy is wealthy, the PV power will be first consumed by EPS load and then charges battery.

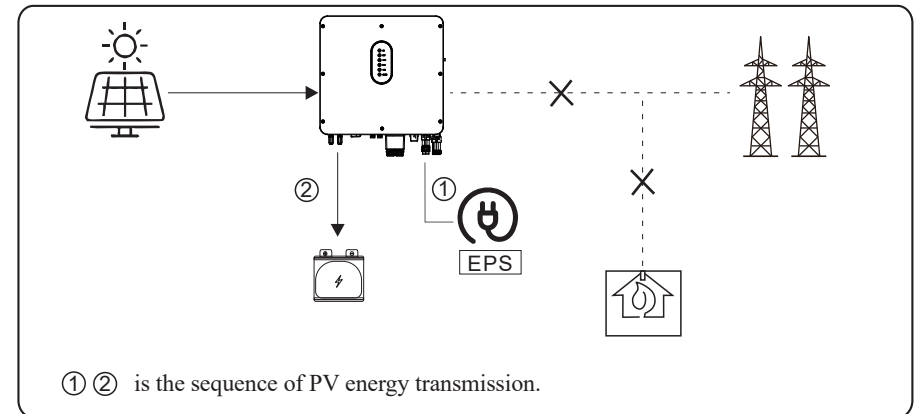

b) Limited PV power

When PV energy is limited, EPS loads are first powered by PV and then supplemented by battery.

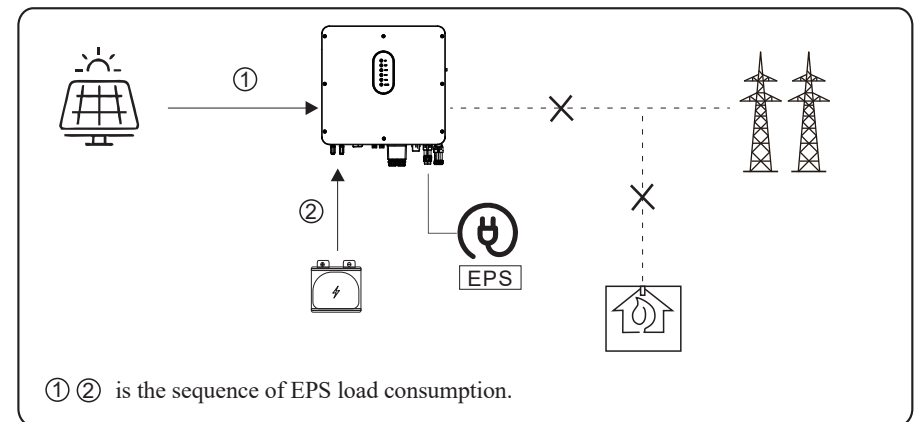

 NOTICE	<ul style="list-style-type: none"> • Under this mode, please complete the output voltage and frequency settings. • It is better to choose the battery capacity larger than 100Ah to ensure EPS function work normally. • If EPS output loads are inductive or capacitive loads, to make sure the stability and reliability of system, it is recommended to configure the power of these loads to be within 50% EPS output power range.
---	---

5.2 Startup/Shutdown the System

5.2.1 Startup the System

Check and confirm the installation is secure and strong enough and that the system grounding is OK. Then confirm the connections of AC, battery, PV etc. are correct. Confirm the parameters and configurations conform to relevant requirements.

AC Frequency	50/60Hz	PV Voltage	90~530V
Battery Voltage	42~60V	Grid AC Voltage	180~270V

Make sure all the above aspects are right, then follow the procedure to start up the inverter:

- 1) Power on the AC.
- 2) Power on the PV. (N/A for AC Couple)
- 3) Power on the battery.
- 4) Connect the cell phone App via blue-tooth. Please refer to Section 7.2 for details.
- 5) Click the Power ON on the App for the first time. Please refer to Section 7.2 for details.

5.2.2 Shutdown the System

According to actual situation, if have to shut-down the running system, please follow below procedure:

- 1) Connect the cell phone App via blue-tooth. Please refer to Section 7.2 for details.
- 2) Click the Power OFF on the App. Please refer to Section 7.2 for details.
- 3) Unpower off the battery.
- 4) Unpower off the PV. (N/A for AC Couple)
- 5) Unpower off the AC.
- 6) If need to disconnect the inverter cables, please wait at least 5 minutes before touching these parts of inverter.

6. Commissioning

It is necessary to make a complete commissioning of the inverter system. This will essentially protect the system from fire, electric shock or other damages or injuries.

6.1 Inspection

Before commissioning, the operator or installer (qualified personnel) must inspect the system carefully and make sure:

- 1) The system is firmly installed correctly following the contents and notifications of this manual, and there are enough spaces for operation, maintenance and ventilation.
- 2) All the terminals and cables are in good status without any damages.
- 3) No items are left on the inverter or within the required clearance section.
- 4) The PV, battery pack is working normally, and grid is normal.

6.2 Commissioning Procedure

After the inspection and make sure status is right, then start the commissioning of the system.

- 1) Power on the system by referring to the Startup section 5.2.1.
- 2) Setting the parameters on the App according to user's requirement.
- 3) Finish commissioning.

7. User Interface

7.1 LED

This section describes the LED panel. LED indicator includes PV, BAT, GRID, EPS, COM, ALARM indicators. PV is N/A for AC couple. It includes the explanation of indicator states and summary of indicator states under the running state of the machine.

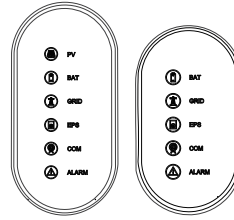

LED Indicator	Status	Description
PV	On	PV input is normal.
	Blink	PV input is abnormal.
	Off	PV is unavailable.
BAT	On	Battery is charging.
	Blink	Battery is discharging. Battery is abnormal.
	Off	Battery is unavailable.
GRID	On	GRID is available and normal.
	Blink	GRID is available and abnormal.
	Off	GRID is unavailable.
COM	On	Communication is ok.
	Off	Power supply is unavailable.
EPS	On	EPS power is available.
	Blink	EPS output is abnormal.
	Off	EPS power is unavailable.
ALARM	On	Fault has occurred and inverter shuts down.
	Blink	Alarms has occurred but inverter doesn't shut down.
	Off	No fault.

Details	Code	PV LED	Grid LED	BAT LED	EPS LED	COM LED	ALARM LED
PV normal		●	○	○	○	○	○
No PV		○	○	○	○	○	○
PV over voltage	B0						
PV under voltage	B4						
PV irradiation weak	B5	★	○	○	○	○	○
PV string reverse	B7						
PV string abnormal	B3						
On grid		○	●	○	○	○	○
Grid over voltage	A0						
Grid under voltage	A1						
Grid absent	A2						
Grid over frequency	A3	○	★	○	○	○	○
Grid under frequency	A4						
Grid abnormal	A6						
Grid over mean voltage	A7						
Neutral live wire reversed	A8						
Battery in charger		○	○	●	○	○	○
Battery absent	D1	○	○	○	○	○	○
Battery in discharge		○	○	★★	○	○	○
Battery under voltage	D3						
Battery over voltage	D2						
Battery discharge over current	D4	○	○	★	○	○	○
Battery over temperature	D5						
Battery under temperature	D6						
Communication loss (Inverter - BMS)	D8						
EPS output active		○	○	○	●	○	○
EPS output inactive		○	○	○	○	○	○
EPS short circuit	DB						
EPS over load	DC						
EPS output voltage abnormal	D7	○	○	○	★	○	○
EPS over dc-bias voltage	CP						

Details	Code	PV LED	Grid LED	BAT LED	EPS LED	COM LED	ALARM LED
WLAN/RS485/DB9/BLE/USB		☉	☉	☉	☉	●	☉
Inverter over temperature	C5						
Fan abnormal	C8						
Inverter in power limit state	CL						
Data logger lost	CH	☉	☉	☉	☉	☉	★
Meter lost	CJ						
Remote off	CN						
PV insulation abnormal	B1						
Leakage current abnormal	B2						
Internal power supply abnormal	C0						
Inverter over dc-bias current	C2						
Inverter relay abnormal	C3						
GFCI abnormal	C6						
System type error	C7						
Unbalance Dc-link voltage	C9						
Dc-link over voltage	CA	☉	☉	☉	☉	☉	●
Internal communication error	CB						
Internal communication loss(E-M)	D9						
Internal communication loss(M-D)	DA						
Software incompatibility	CC						
Internal storage error	CD						
Boost abnormal	CG						
Dc-dc abnormal	CU						

Remark: ● Light on ○ Light off ☉ Keep original status
 ★ Blink 1s and off 1s ★★ Blink 2s and off 1s

7.2 App Setting Guide

This section takes V6.4.5 as an example.

7.2.1 Download App

- Launch your browser, enter <http://www.senergytec.cn> on the address bar and press enter to scan the QR code to install **SETouch** App for the android users.
- Searching **SETouch** in the Apple App Store to install it for the IOS users.

The APP should access some permissions such as device’s location. You can allow them when you install the APP or grant permissions in your own phone setting.

7.2.2 App Architecture

SETouch contains “Cloud Login” and “Local Connection”.

- Cloud login: APP read data from cloud server through API and display inverter parameter
- Local connection: APP read data from inverter through Bluetooth connection with Modbus protocol to display and configure inverter parameter.

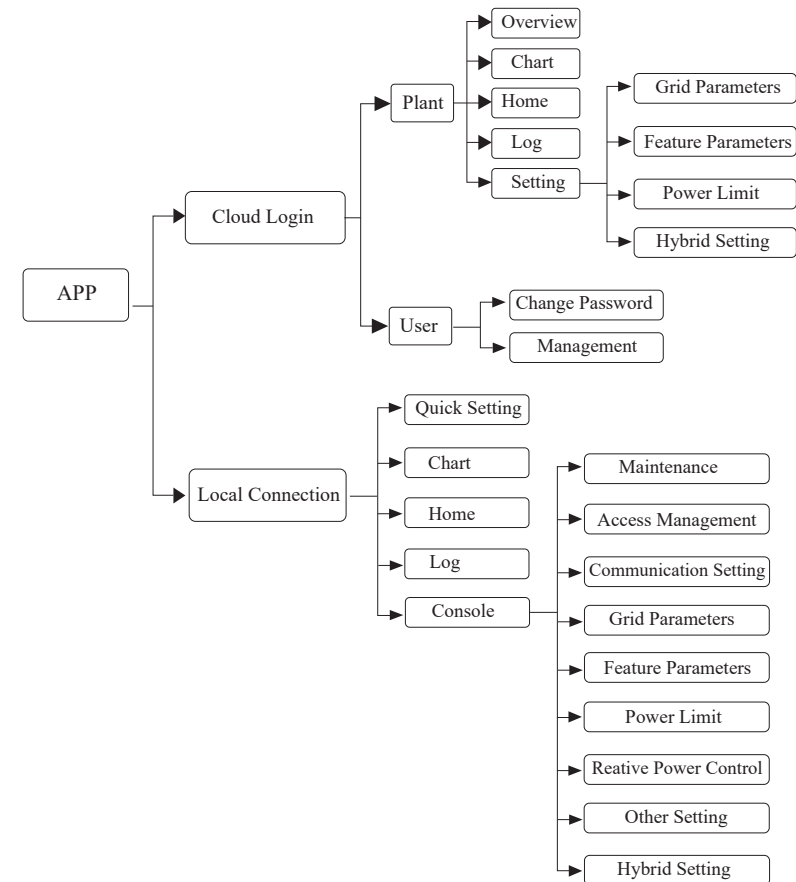

7.2.3 Local Setting

Access Permission

Before using the local setting, the APP should access some permissions. (You can allow them when you install the APP or grant permissions in your own phone setting.) When the APP asks for permission, please click Allow.

Connect Inverter

Firstly, open the Bluetooth on your own phone, then open the APP.

Press Local Setting to go to the connect page. This page shows the inverters which you can connect or you have connected. (As shown below) Press the inverter's name to connect it.

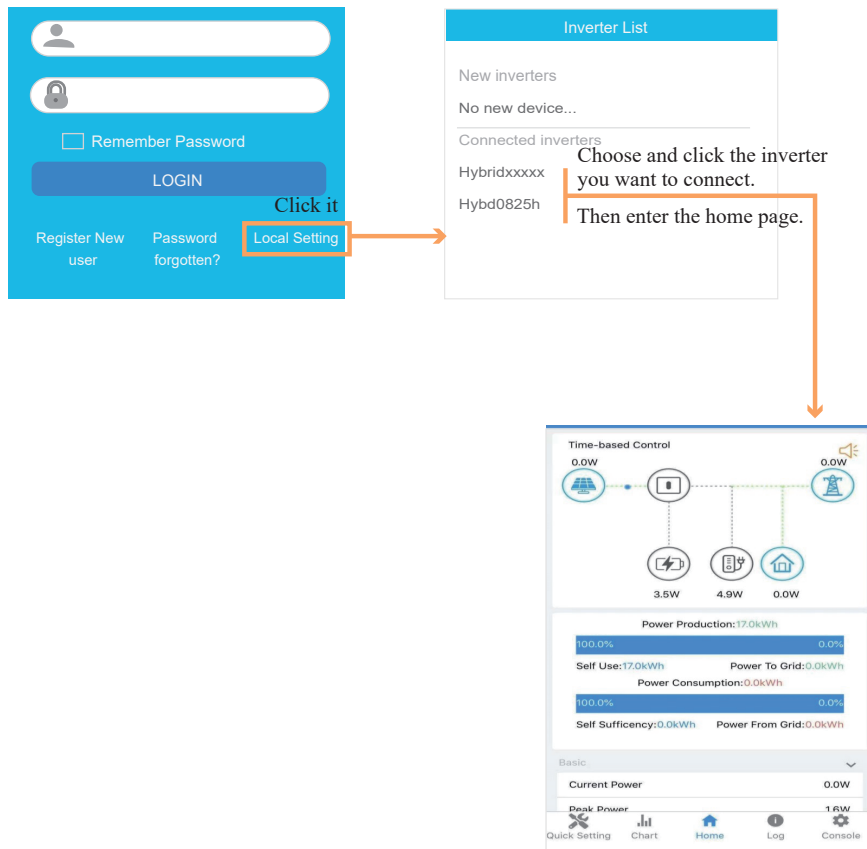

Quick Setting

1. Connect to the router.

Step 1 Click each item to enter the informations.

Step 2 Click **Next**.

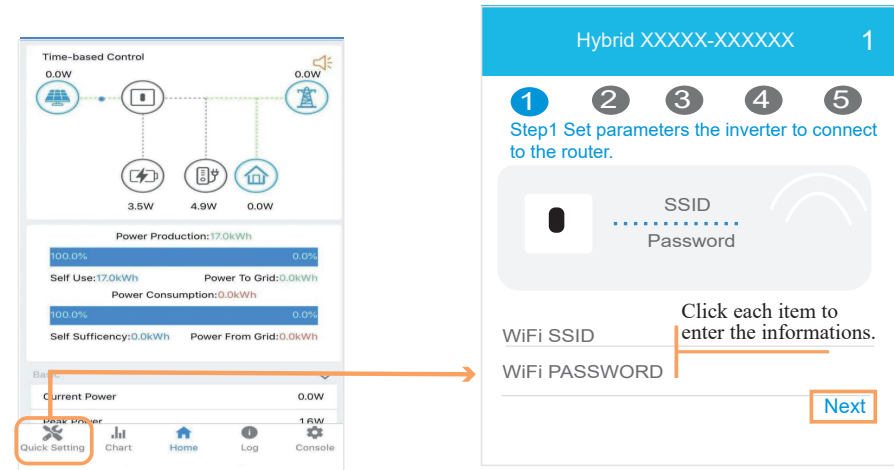

2. Set parameters of power grid

Step 1 Click each item to enter the parameters of power grid.

Step 2 Click **Next**.

Step 3 Click **Previous** back to the previous page.

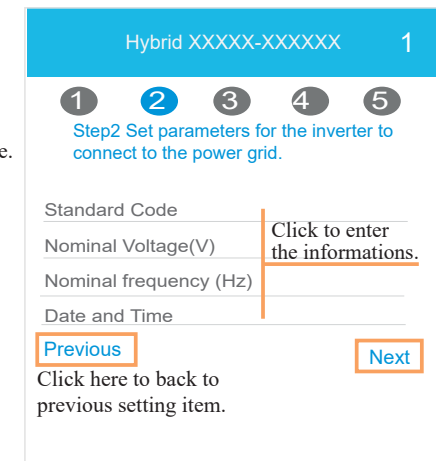

3. Set parameters of power limit

- Step 1 Click each item to enter the parameters of power limit.
- Step 2 Click [Next](#).
- Step 3 Click [Previous](#) back to the previous page.

Click each item to enter the informations.

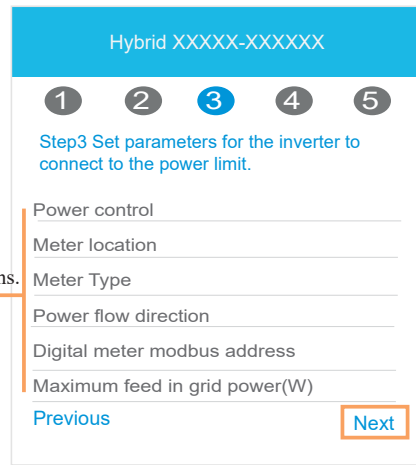

4. Set parameters of work mode

- Step 1 Click each item to enter the informations of work mode.
- Step 2 Click [Next](#).
- Step 3 Click [Previous](#) back to the previous page.

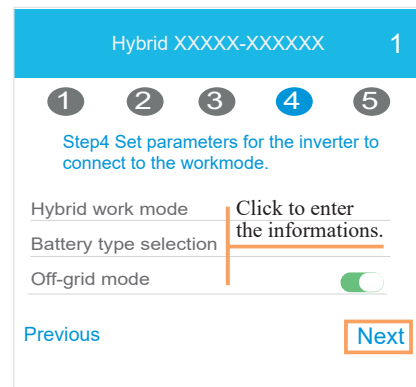

5. Start Inverter

- Step 1 Click .
- Step 2 Click [Previous](#) back to the previous page.

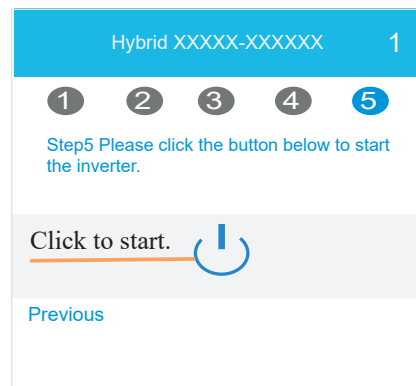

■ Chart

Under this menu, you can check the relevant data curve of energy (including Daily, Monthly and Annual).

1. Query(Daily) Data

Go to [Chart](#) > [Day](#) page. It will show the Daily Production or Consumption Curve in this page. You can swipe the screen left and right to switch the graph.



Different color curves represent energy data of different the icon.

Click the icon to show and hide the corresponding curve of the corresponding content.

Click the curves to display the specific data.

You can also press the date such as “2021-10-28” in the figure to choose the day which you want to check. Or click the left and right arrows to switch the data of the day before yesterday and tomorrow (as shown in the Figure)



2. Query(Monthly or Yearly) Data

Go to **Chart > Month** or **Year** page. It will show the Daily Production or Consumption bars in this page. You can swipe the screen left and right to switch the graph. And the specific operation of checking data is the same as daily.

Daily data retention: 7 days

Monthly data retention: 36 months

yearly data retention: 10 years

Local Setting Homepage

This page shows the basic information of inverter. Click to display the warning message.

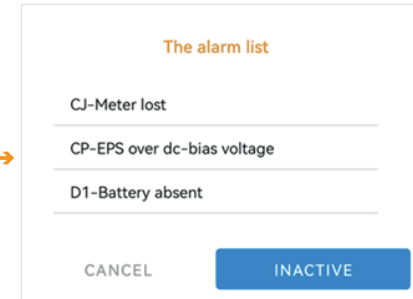
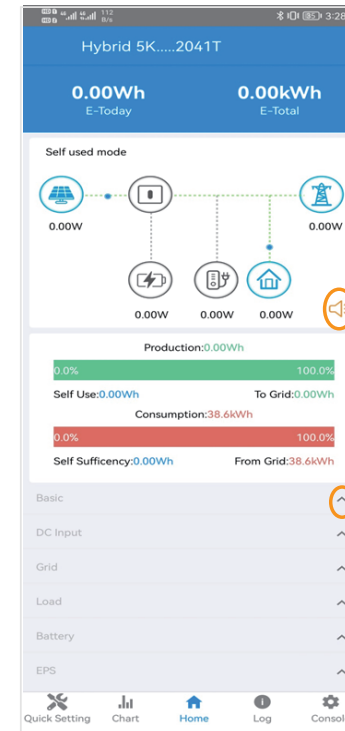

Click here to expand.

History Log

Press **Log** at the bottom and then go to the history log page (as shown below). It contains all the logs for the inverter.

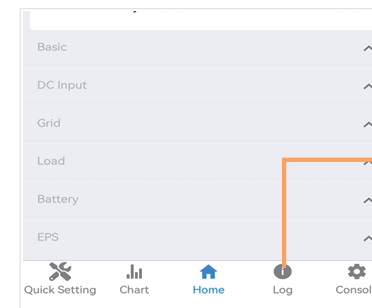

■ Maintenance

Go to [Console](#) page. And click [Maintenance](#)

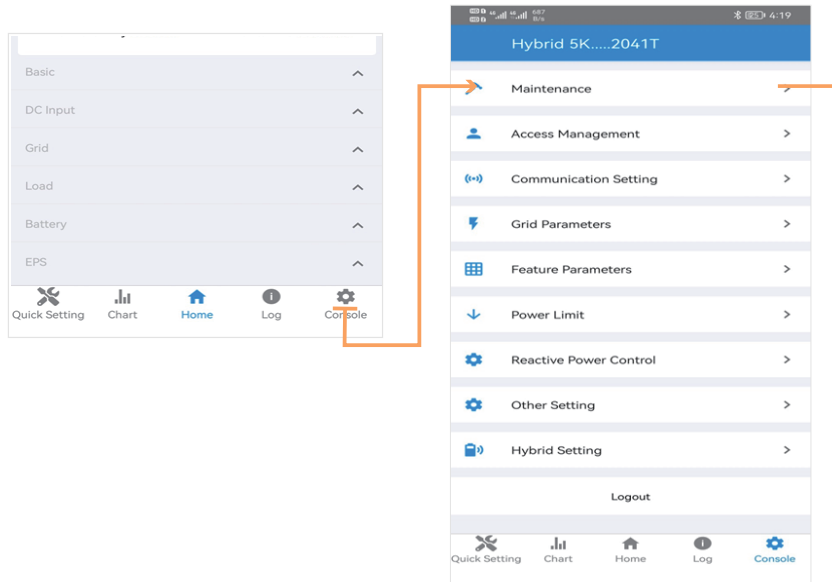

Then you need to enter password in a popup window (as shown below).

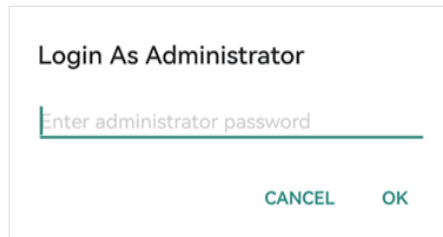

You can burn software, switching device, do import and export functions in this page.

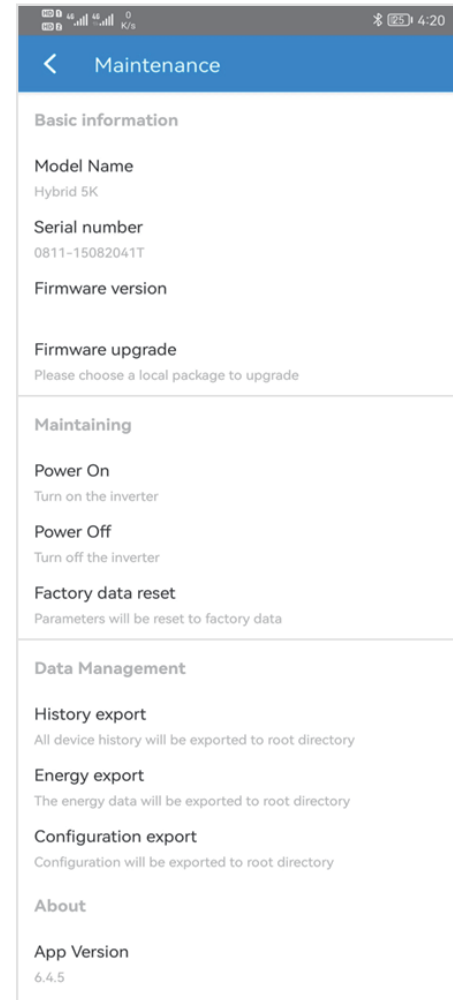

■ Console

Access Management

Go to [Console > Access Management](#) page. In this page, you can switch the login permission and modify login password.

Change User: Enter administrator password to login as administrator or guest.

Modify Login Password: You can modify login password when you login as administrator.

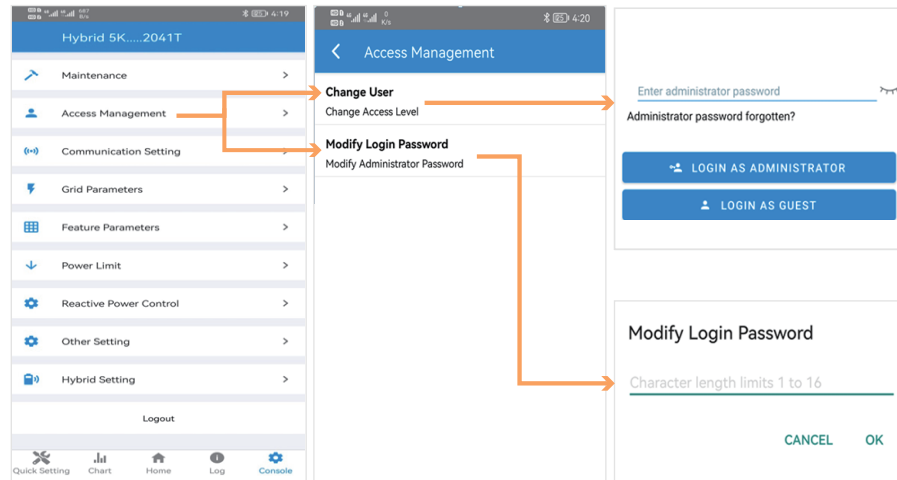

Communication Setting

Go to [Console > Communication Setting](#) page. In this page, you can set or change the parameters of communication settings: Basic Setting, RS485 Setting and Ethernet Setting.

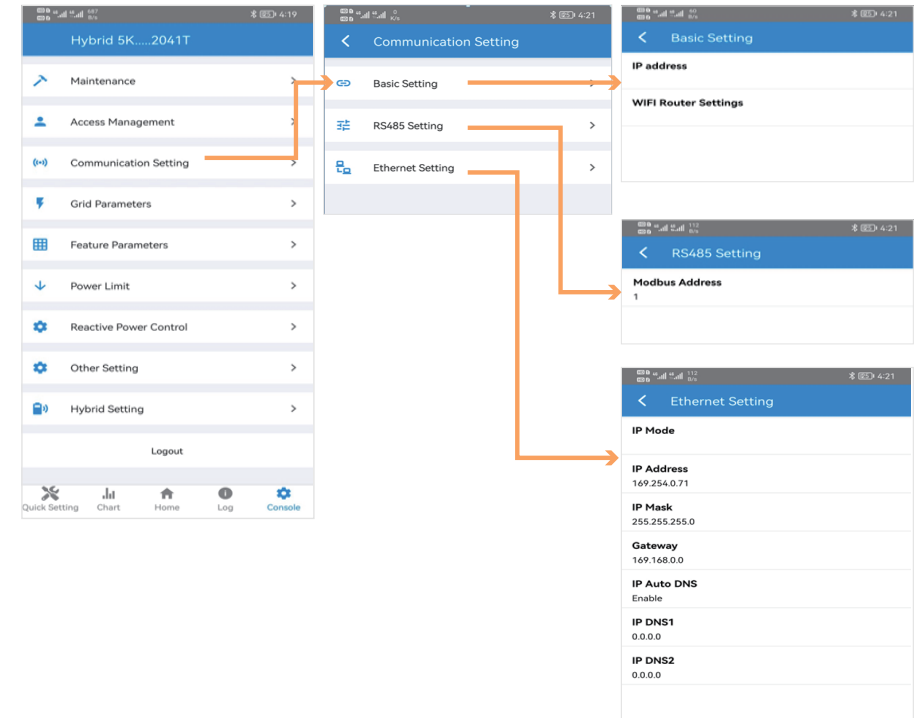

Grid Parameters

Go to [Console > Grid Parameters](#) page. In this page, you can set or change the parameters of Grid side, as shown in the figure.

Feature Parameters

Go to [Console > Feature Parameters](#) page. In this page, you can set or change the feature parameters, as shown in the figure.

Power Limit

Go to [Console > Power Limit](#) page. In this page, you can set or change the parameters of power limit, as shown in the figure.

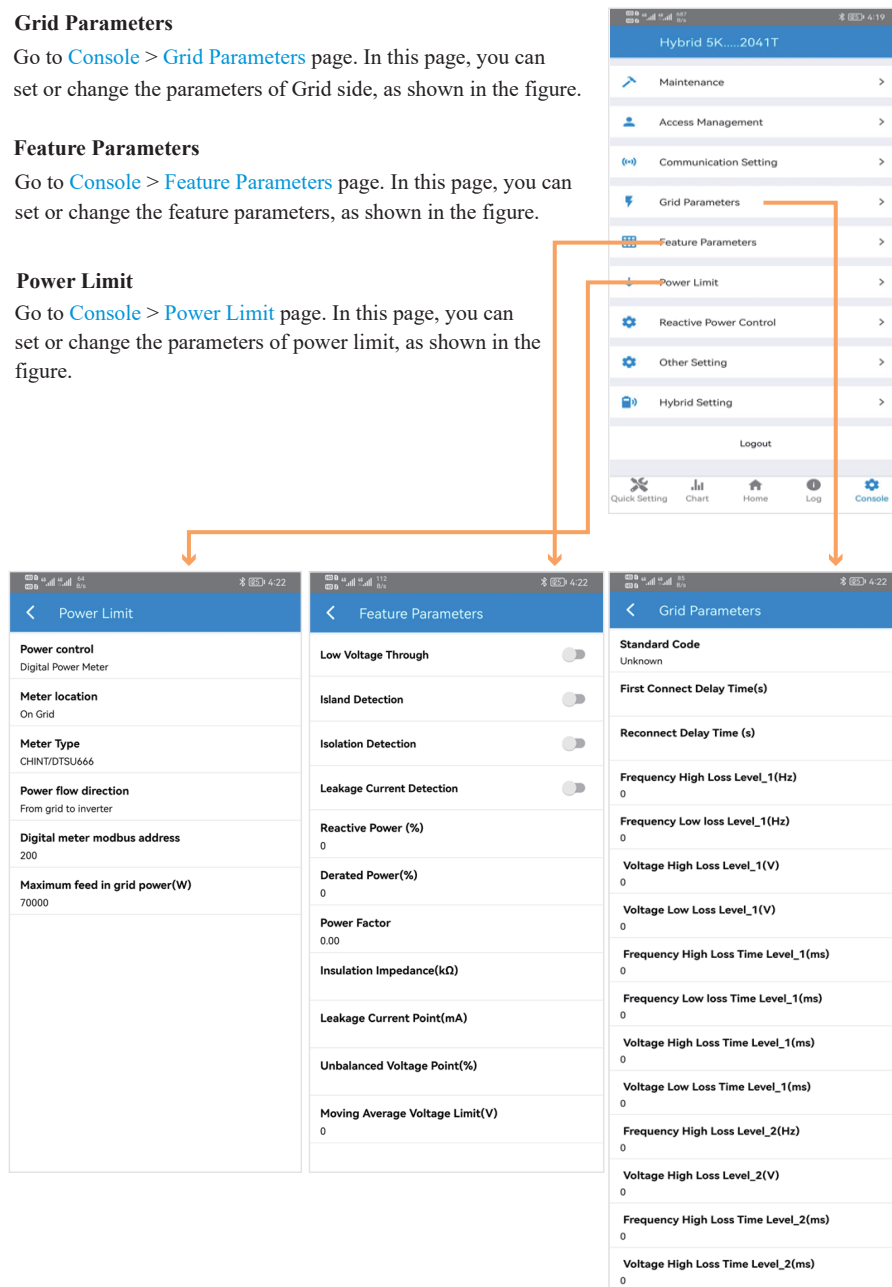

Reactive Power Control

Go to [Console > Reactive Power Control](#) page. In this page, you can set or change the Reactive Power Control parameters.

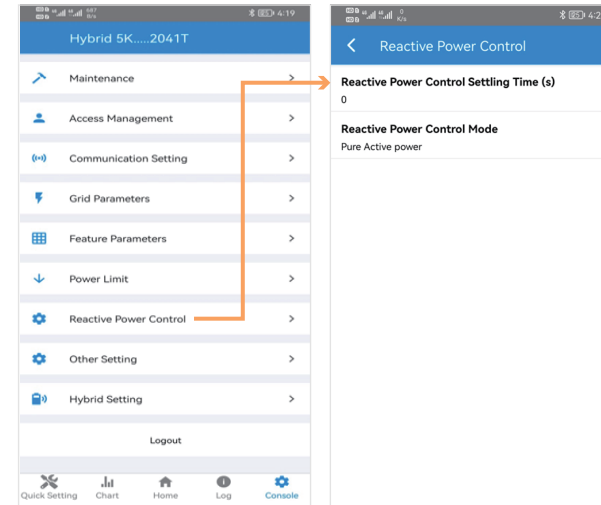

Other Setting

Go to [Console > Other Setting](#) page. In this page, you can set other setting parameters.

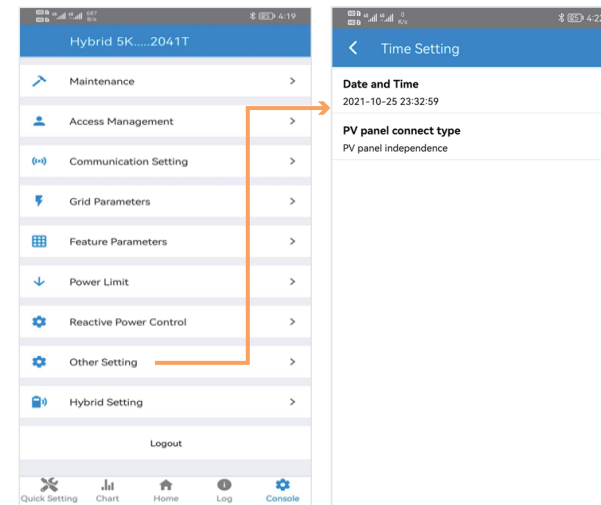

Hybrid Setting

Go to [Console > Hybrid Setting](#) page. In this page, you can set Hybrid Setting parameters.

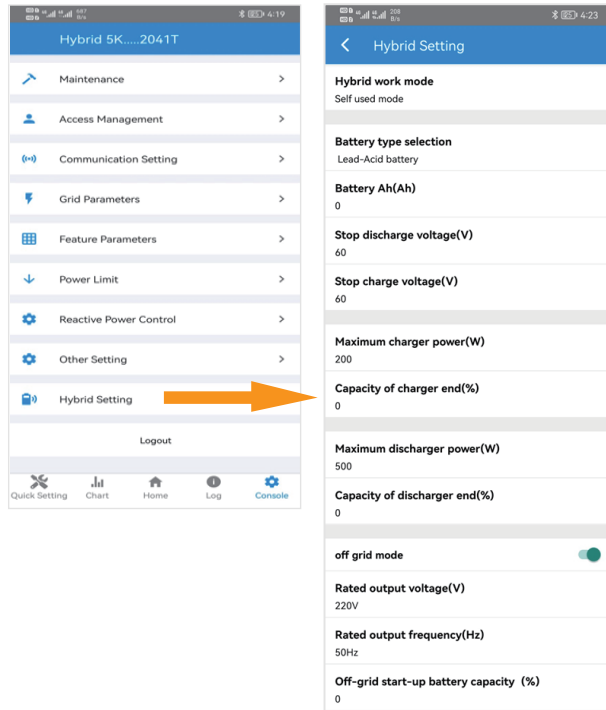

8. Maintenance

 CAUTION	Before maintaining and commissioning inverter and its peripheral distribution unit, switch off all the charged terminals of the inverter and wait at least 10 minutes after the inverter is powered off.
--	--

8.1 Routine Maintenance

Items	Check Content	Maintain Content	Maintenance Interval
Inverter output status	Statistically maintain the status of electrical yield, and remotely monitor its abnormal status.	N/A	Weekly
PV inverter cleaning	Check periodically that the heat sink is free from dust and blockage.	Clean periodically the heat sink.	Yearly
PV inverter running status	Check that the inverter is not damaged or deformed. Check for normal sound emitted during inverter operation. Check and ensure that all inverter communications is running well.	If there is any abnormal phenomenon, replace the relevant parts.	Monthly
PV inverter electrical connections	Check that all AC, DC and communication cables are securely connected; Check that PGND cables are securely connected; Check that all cables are intact and free from aging.	If there is any abnormal phenomenon, replace the cable or re-connect it.	Semiannually

8.2 Inverter Troubleshooting

When the inverter has an exception, its basic common warning and exception handling methods are shown below.

Code	Alarm Information	Suggestions and measures
A0	Grid over voltage	1. If the alarm occurs occasionally, possibly the power grid voltage is abnormal for a short time, and no action is required.
A1	Grid under voltage	2. If the alarm occurs repeatedly, contact the local power station. After receiving approval of the local power bureau, revise the electrical protection parameters settings on the inverter through the App.
A3	Grid over frequency	
A4	Grid under frequency	3. If the alarm persists for along time, check whether the AC circuit breaker /AC terminals is disconnected or not, or if the grid has a power outage.
B0	PV over voltage	Check the number of PV modules and adjust it if necessary.
B1	PV insulation abnormal	1. Check the insulation resistance against the ground for the PV strings. If a short circuit has occurred, rectify the fault. 2. If the insulation resistance against the ground is less than the default value in a rainy environment, set insulation resistance protection on the App.
B2	Leakage current abnormal	1. If the alarm occurs occasionally, the inverter can automatically recover to the normal operating status after the fault is rectified. 2. If the alarm occurs repeatedly, contact your dealer for technical support.
A2	Grid absent	Wait till power is restored.
B7	PV string reverse	Check whether the cables of PV strings are correctly connected. If they are connected reversely, reconnect the cables.
B3	PV string abnormal	1. Check whether the PV string is shielded. 2. If the PV string is clean and not shielded, check whether the PV modules are aging or deteriorated.
B4	PV under voltage	1. If the alarm occurs occasionally, possibly the external circuits are abnormal accidentally. The inverter automatically recovers to the normal operating status after the fault is rectified. 2. If the alarm occurs repeatedly or last a long time, check whether the insulation resistance against the ground of PV strings is too low.

Code	Alarm Information
CF	Inverter abnormal
CG	Boost abnormal
B5	PV irradiation weak
A6	Grid abnormal
C1	Arc fault detection
A7	Grid over mean vltage
C2	Inverter over DC-bias current
C3	Inverter relay abnormal
CN	Remote off
C5	Inverter over temperature
C6	GFCI abnormal
C0	Internal power supply abnormal
C7	System type error
C8	Fan abnormal
C9	Unbalance DC-link voltage
CA	DC-link over voltage
CB	Internal communication error
CC	Software incompatibility
CD	Internal storage error
CE	Data inconsistency
CH	Data loger lost
CJ	Meter lost
D1	Battery absent

Code	Alarm Information
D2	Battery over abnormal
D3	Battery under voltage
D4	Battery discharge over current
D5	Battery over temperature
D6	Battery under temperature
A8	Neutral live wire reversed
D7	EPS output voltage abnormal
D8	Communication error (Inverter - BMS)
D9	Internal communication loss (E-M)
DA	Internal communication loss (M-D)
CU	DC abnormal
CP	EPS over DC-bias voltage
CL	Inverter in power limit state

8.3 Removing the Inverter

 WARNING	Before removing DC input connector, double check DC input switch is turned to OFF to avoid inverter damage and personal injury.
--	---

Perform the following procedures to remove the inverter:

Step 1. Disconnect all cables from the inverter, including communications cables, DC input power cables, AC output power cables, and PGND cable, as shown below.

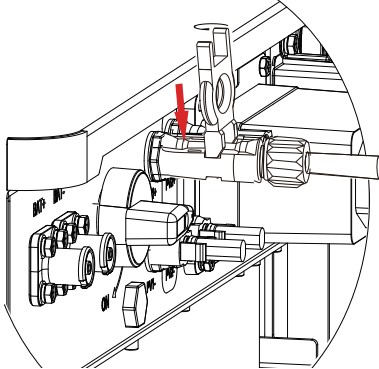

PV Connectors Removing Detail

 **NOTE**

To remove the PV/Grid/EPS connectors, insert the removal tool into the bayonet according to the position indicated in the drawing, press inward, and then take out the connector outward.

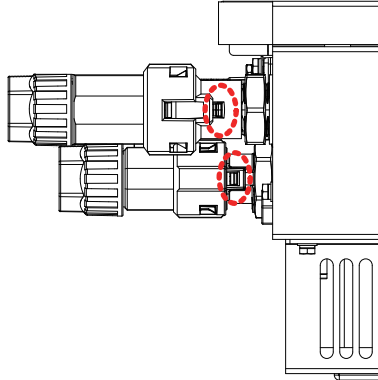

Grid/EPS Connectors Removing Detail

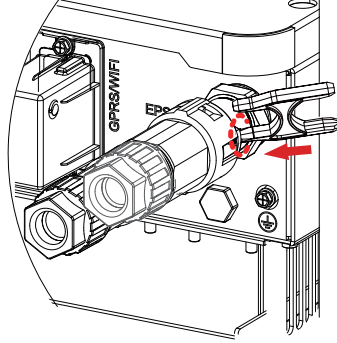

Step 2. Remove the inverter from the mounting bracket.

Step 3. Remove the mounting bracket.

9. Technical Specifications

Model	SE4K6HB-60	SE 4K6HB-120	SE 5KHB-60	SE 5KHB-120	SE 6KHB-60	SE 6KHB-120	SE 4K6AC	SE 5KAC	SE 6KAC
Efficiency									
Max. efficiency (PV to AC)	97.3%						N/A		
Max. efficiency (BAT to AC)	94.0%						94.0%		
Input (PV)									
Max. PV power (W)	9000						N/A		
Max. PV voltage (V)	550						N/A		
Max. input current (A)	15/15						N/A		
Max. short current (A)	20/20						N/A		
Startup voltage (V)	90						N/A		
MPPT voltage range @full load (V)	200~480	200~480	200~480	200~480	230~480	230~480	N/A		
No. of MPPT trackers	2						N/A		
String per MPPT tracker	1						N/A		
Input (BAT)									
Compatible battery type	Lithium/Lead-acid						Lithium/Lead-acid		
Norminal battery voltage (V)	48						48		
Battery voltage range (V)	40~60						40~60		
Lithium battery charge curve	Self-adaption to BMS						Self-adaption to BMS		
Max. charge/discharge current (A)	60/60	120/120	60/60	120/120	60/60	120/120	100/100	100/100	120/120
Max. charge/discharge power (W)	3000/3000	6000/6000	3000/3000	6000/6000	3000/3000	6000/6000	5000/5000	5000/5000	6000/6000

Model	SE4K6HB-60	SE 4K6HB-120	SE 5KHB-60	SE 5KHB-120	SE 6KHB-60	SE 6KHB-120	SE 4K6AC	SE 5KAC	SE 6KAC
Output (Grid)									
Nominal AC output power (W)	4600	4600	5000	5000	6000	6000	4600	5000	6000
Max.AC output apparent power (VA)	4600	4600	5500	5500	6000	6000	4600	5500	6000
Max.AC output power (PF-1) (W)	4600	4600	5500	5500	6000	6000	4600	5500	6000
Max.AC output current (A)	22	22	25	25	27.2	27.2	22	25	27.2
Rated AC voltage (V)	220						220		
AC voltage range (V)	150~300(adjustable)						150~300(adjustable)		
Rated AC frequency (Hz)	50/60						50/60		
AC frequency range (Hz)	45~55/55~65(adjustable)						45~55/55~65(adjustable)		
Grid connection	Single phase						Single phase		
Power factor	>0.99@rated power(adjustable 0.8LG~0.8LD)						>0.99@rated power(adjustable 0.8LG~0.8LD)		
THDI	<3%						<3%		
Output (Back up)									
Nominal output voltage (V)	230						230		
Nominal output frequency (Hz)	50/60						50/60		
Transfer time (ms)	10(type)/20(max.)						10(type)/20(max.)		
THDV	<3%@100%R load						<3%@100%R load		
Nominal output power (W)	3000	4600	3000	5000	3000	5000	4600	5000	6000
Nominal output current (A)	13	20	13	21.7	13	21.7	20	21.7	26

Model	SE4K6HB-60	SE 4K6HB-120	SE 5KHB-60	SE 5KHB-120	SE 6KHB-60	SE 6KHB-120	SE 4K6AC	SE 5KAC	SE 6KAC
Protection									
Protection category				Class I			Class I		
AC overcurrent protection				Support			Support		
AC short circuit protection				Support			Support		
Leakage current protection				Support			Support		
AC overvoltage category				III			III		
PV overvoltage category				II			N/A		
Surge Arrester				DC Type III; AC Type III			AC Type III		
DC switch				Support			N/A		
Anti-islanding protection				Support			Support		
DC reverse connection				Support			N/A		
Insulation detection				Support			Support		
General									
Topology				Transferless			Transferless		
Max. operation altitude (m)				4000			4000		
Ingress protection degree				IP65			IP65		
Operating temperature range (°C)				-25~60			-25~60		
Noise emission (dB)	<=30	<=35	<=30	<=35	<=30	<=35	<=35		
Weight (kg)	20	25	20	25	20	25	20		

Model	SE4K6HB-60	SE 4K6HB-120	SE 5KHB-60	SE 5KHB-120	SE 6KHB-60	SE 6KHB-120	SE 4K6AC	SE 5KAC	SE 6KAC
Relative humidity (%)	0~100						0~100		
Cooling concept	Natural						Natural		
Mounting	Wall bracket						Wall bracket		
Dimensions (W*H*D)	(515*487*175)mm						(515*487*175)mm		
PV connection way	MC4/H4						N/A		
Battery connection way	Dedicated DC connector						Dedicated DC connector		
AC connection way (Grid & back up)	Dedicated AC connector						Dedicated AC connector		

Display & Communication

Display	LED+APP						LED+APP		
Communication interface	BMS (CAN/RS485)/Ethernet/WiFi/GPRS/DRMs/Meter (RS485)/USB						BMS (CAN/RS485)/Ethernet/WiFi/GPRS/DRMs/Meter (RS485)/USB		

Certification

Grid	IEC61727; VDE-AR-N4105; VDE0126-1-1; CEI0-21; EN50549; AS4777						IEC61727; VDE-AR-N4105; VDE0126-1-1; CEI0-21; EN50549; AS4777		
Safety	IEC62109-1&2; IEC62477-1; IEC62040-1						IEC62109-1&2; IEC62477-1; IEC62040-1		
EMC	IEC61000-6-1/2/3/4						IEC61000-6-1/2/3/4		

Warranty

Period (Years)	5/10 (optional)						5/10 (optional)		
----------------	-----------------	--	--	--	--	--	-----------------	--	--

As the technology is constantly updated and improved, the illustrations in this document are for reference only. Contents include illustrations in this document are subject to change without notice. All rights reserved