

1. Overview

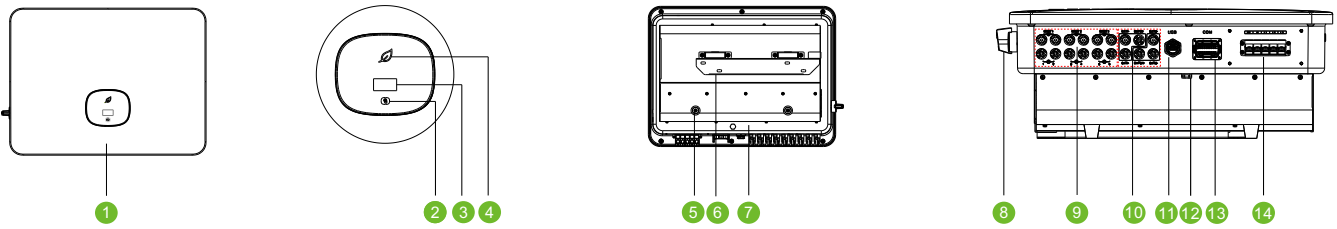

- | | | | | |
|--------------------|------------------|----------------|-------------------|-----------------------|
| (1) Front panel | (2) Touch button | (3) LCD screen | (4) LED indicator | (5) Case feet |
| (6) Mounting plate | (7) Heat sink | (8) DC switch | (9) PV terminal | (10) Battery terminal |
| (11) USB port | (12) Vent valve | (13) COM port | (14) AC terminal | |

▲ Note:

- For MID 11-20KTL3-XH inverters, the PV3 terminal is replaced by a M12 waterproof cap.
- This document serves as a guide for quick installation only. For details, please refer to the User Manual.
- Growatt shall not be liable for any damages caused by improper installation.

2. Installation

System overview

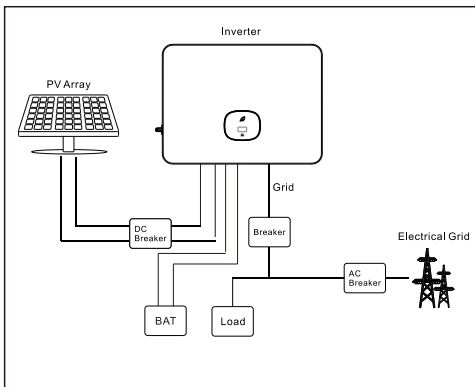

2.1 Installation requirements

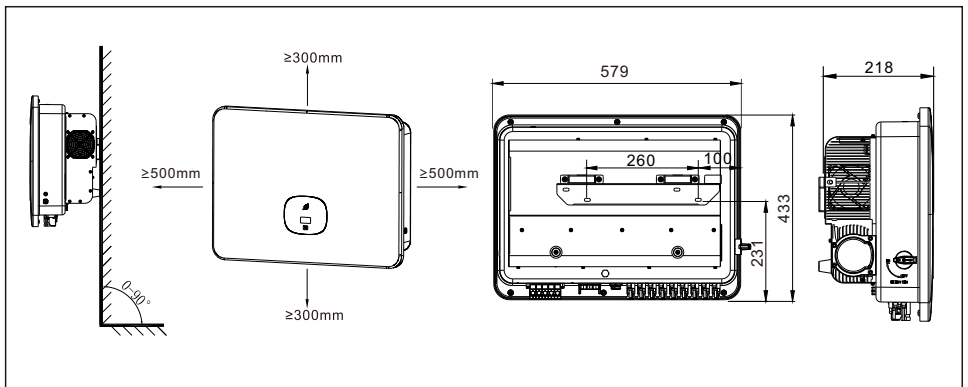

2.2 Wall-mounted installation

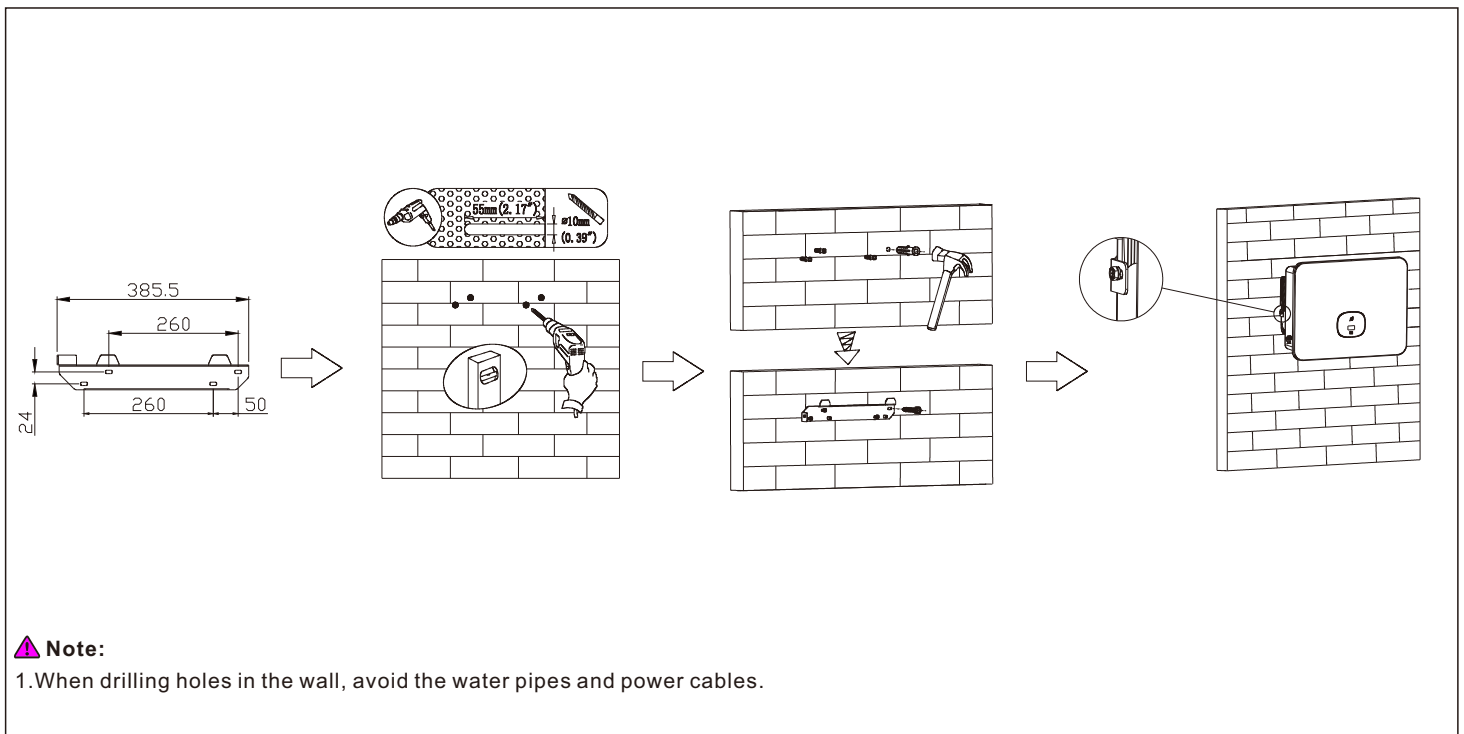

▲ Note:

- When drilling holes in the wall, avoid the water pipes and power cables.

2.3 Installing the communication module

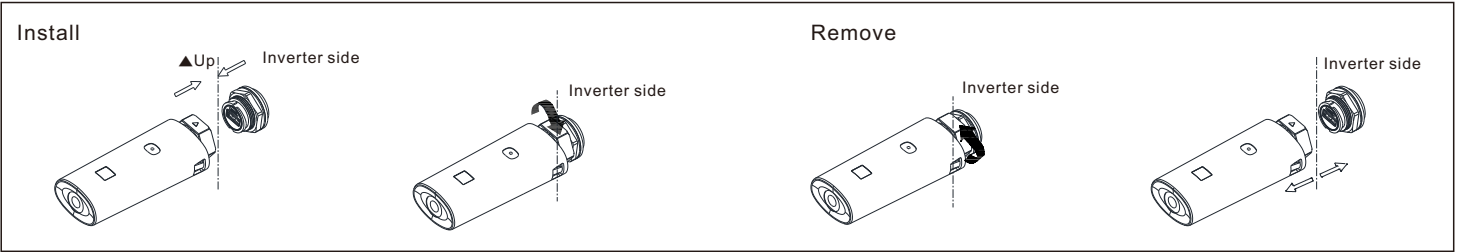

3. Electrical connection

Please prepare the cables before the electrical connection.

No.	Cable	Type	Recommended specification
1	PE cable	Angle multi-core yellow-green cable	6mm ² -10mm ²
2	AC output cable	Two or three multicolored multi-core copper cables	8mm ² -10mm ²
3	PV input cable	PV cable	4mm ² -6mm ²
4	Communication cable	RS485	/

⚠ Note:

1. Please make sure that all switches are off. For safety reason, no work should be done on energized electrical circuits.
2. If the diameter of the cable does not match the terminal, or the cable is aluminum wire, please contact our after-sales personnel.

3.1 Grounding

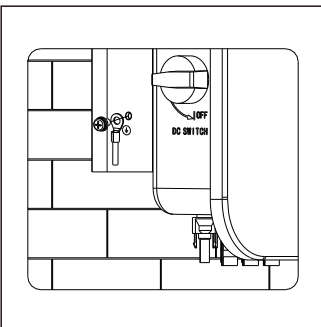

3.2 Connecting the AC output cable

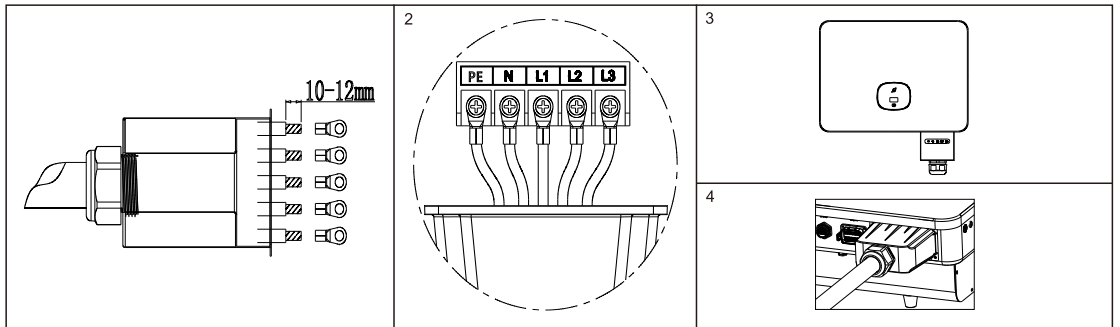

⚠ Note:

1. The waterproof cap must be applied with the fireproof mud to prevent water.
2. For XH L series inverters, you do not need to connect the N line.

3.3 DC connection

3.3.1 PV input terminal installation

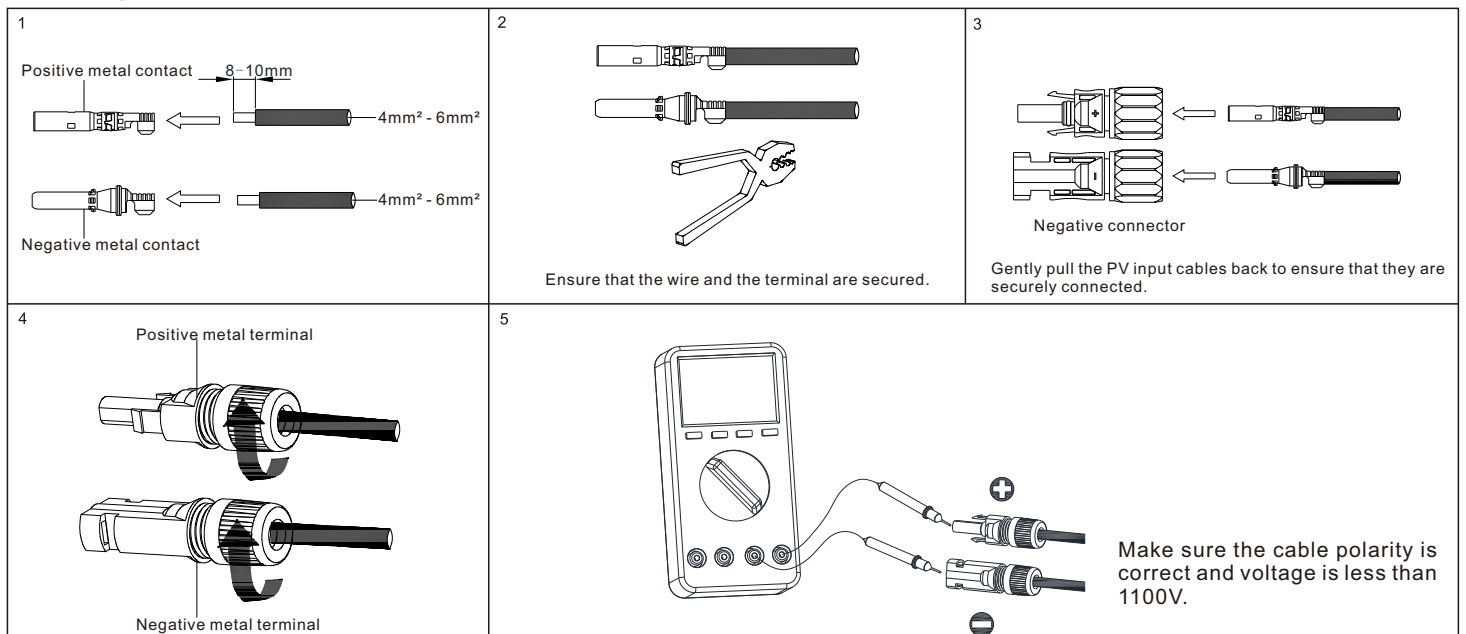

3.3.2 Connecting the PV/BAT terminals

1

2

▲ Note:

1. Before installing the PV terminal, please double-check that the PV input voltage and current do not exceed the MPPT limits.
2. Ensure the correct polarity when connecting the positive and negative PV terminals to the inverter.
3. Ensure that you hear a "click" sound which indicates a robust connection. Gently pull the cables back to ensure that they are securely connected.

3.3.3 Connecting the communication cable

The Inverter Side

connect to RRCR

No.	Description	Function
1	+12V	Dry contact: the power of any external wiring connected to it should not be greater than 2W
2	COM	
3	RS485A1	RS485 communication port
4	RS485B1	
5	RS485A3	Meter communication port
6	RS485B3	
7	RS485A2	Battery communication port
8	RS485B2	
9	BAT.EN+	Battery wake-up signal
10	BAT.EN-	
11	DRM1/5	Relay contact 1 input
12	DRM2/6	Relay contact 2 input
13	DRM3/7	Relay contact 3 input
14	DRM4/8	Relay contact 4 input
15	REF/GEN	GND
16	DRM0/COM	/
21	BOX.EN+	Backup box identification signal
22	BOX.EN-	
23	RS485A4	Backup box communication
24	RS485B4	
27	RS485A2	Battery communication port 2
28	RS485B2	
29	BAT.EN+	Battery wake-up signal 2
30	BAT.EN-	

▲ Note:

1. When connecting the communication cable, do not connect to Port 15 and Port 16. For other port definitions, please refer to the table above.
2. When connecting to the battery, Port 9 and Port 10 must be connected.

4. Connecting the Meter and the Backup Box

The following diagrams illustrate the way to connect the EASTRON meter (TOM-E) and the Backup Box to the inverter:

▲ Note:
If a backup box is connected, please enable it when configuring the inverter. For details, please refer to Section 9.3.3 in the MID 11-30KTL3-XH User Manual.

5. Post-installation check

No.	Acceptance criteria	No.	Acceptance criteria
1	The inverter is installed correctly, firmly and reliably.	6	The RS485 communication cable is installed correctly and firmly.
2	The PE cables are properly and securely connected.	7	The cable ties are well-trimmed, without any sharp edges
3	All switches are OFF.	8	All exposed terminals are well protected and there are no vacant ports.
4	All electrical connections are correct and secured.	9	Remove the installation residues.
5	The cable wiring is reasonable and meets all requirements. No frayed or cracked wire is used.		

6. Powering on/off the inverter

▲ Note:

Before turning the inverter on, please make sure the PV input voltage and current are within the MPPT limits.

Follow the steps below to turn the inverter on:

1. Switch on the built-in DC switch at the bottom of the inverter.
2. Switch on the PV Array and DC isolator next to your inverter. If the switch is not available, skip this step.
3. Switch on the Solar AC isolator if the inverter is more than 3 meters away from your switchboard.
4. Switch on the solar supply main switch in the switch board.

To shut down your system, follow the reverse order of the steps mentioned above.

7. Status of PV grid inverter

You can view information by pressing the button.

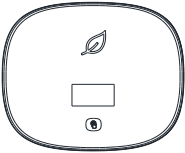
Symbol	Description	Explanation	
	Touch button	Single tap	Switch the display interface or increase the value by one
		Double tap	Access the settings or confirm your setting
		Triple tap	Return to the previous display interface
		Long press for 5s	Restore to factory settings
	Inverter status indicator	Red	Fault
		Green	Normal operation
		Flashing red	Warning
		The LCD screen displays the basic information about the inverter, including PV/AC voltage, PV power, AC current, the total power and capacity.	

8. Export limitation setting

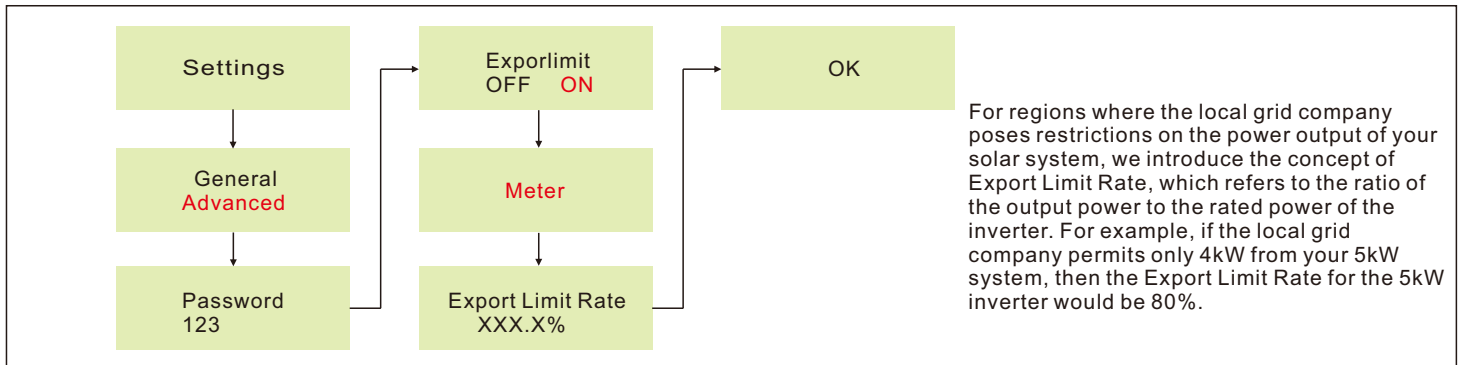

9. Service and contact

Shenzhen Growatt New Energy Co., Ltd
 4-13/F, Building A, Sino-German (Europe) Industrial Park,
 Hangcheng Ave, Bao'an District, Shenzhen, China

T +86 755 2747 1942
 E service@ginverter.com
 W www.ginverter.com



Download
Manual



 Growatt New Energy