



High Voltage Battery System

Battery-Box

HVS+ 5.1, 7.7, 10.2, 12.8

HVM+ 8.3, 11.0, 13.8, 16.6, 19.3, 22.1

User Manual



iOS



Android

Copyright©2023 BYD Co., Ltd. All Rights Reserved.

Legal Provisions

All information in this document is the property of BYD Lithium Battery Co., Ltd. (herein after "BYD") and no part of this document may be reproduced in any manner for commercial use.

BYD makes no representations or warranties, express or implied, with respect to this document or any equipment and/or software that may be described in it, including (without limitation) any implied warranties of utility, merchantability or fitness for any particular purpose, and all such representations or warranties are expressly disclaimed. In no event shall BYD or its distributors or dealers be liable for any indirect, incidental or consequential damages.

Under some statutes, the exclusion of implied warranties may not apply in all cases, so the above exclusion may not apply.

This document does not supersede and is not intended to supersede any local, state, provincial, federal, or national laws, regulations, or codes applicable to the installation, electrical safety, and use of the battery module. BYD is not responsible for compliance or non-compliance with such laws or regulations when installing the battery module.

Specifications are subject to change without notice. Every effort has been made to keep this document complete, accurate and current. However, without advance notice, BYD may need to make some improvements in specific situations. BYD shall not be liable for any damage caused by this document, including but not limited to omissions, errors, typographical errors, miscalculations, or tabulation errors in this document.

All trademarks are recognized.

Limited Warranty Letter

You can download the latest Limited Warranty Letter from the www.bydenergy.com on the Internet.

Product Datasheet

You can download the latest Product Datasheet from the www.bydenergy.com on the Internet.

Compatible Inverter List

You can download the latest Compatible Inverter List from the www.bydenergy.com on the Internet.

Service Guide and Checklist

You can download the latest Service Guide and Checklist from the www.bydenery.com on the Internet.

BYD Lithium Battery Co., Ltd.

No. 3001 Baohe Road, Baolong Industrial City, Longgang Street, Longgang District, ShenZhen.

Manufacturer

Shanwei BYD Auto Co., Ltd.

Xinhe Industrial Park, Luhe, Shanwei, P.R.China.

Table of Contents

1 Information on this Document	6
1.1 Validity	7
1.2 Target Groups	7
1.3 Content and Structure of this Document	7
1.4 Loading and Unloading Requirements	7
1.5 Transport Requirements	7
1.6 Declaration of Conformity	8
1.7 Warning Level	8
1.8 Documentation Symbols	8
1.9 Abbreviations and Definitions of Terms	9
2 Security	10
2.1 Intended Use	10
2.2 Important Safety Instructions	11
2.2.1 Battery Module Leakage	11
2.2.2 Firefighting Measures	11
2.2.3 Battery Modules Handling and Storage Guide	12
2.2.4 Warning of Electric Shock	13
2.2.5 Warning of Overvoltage	13
2.2.6 Caution of Weight	14
2.2.7 Notice of Property Damage	14
3 Scope of Delivery	15
3.1 BCU and Base Package	15
3.2 Battery Module Package	16
4 Battery System Overview	17
4.1 Structure Dimension Drawing	17
4.2 Battery System Description	17
4.3 Battery System Scalability	18
4.4 Interface	19
4.5 Symbols	21
4.6 Labels	23
4.6.1 BCU Labels	23
4.6.2 Battery Module Labels	23
4.7 LED Signals	24
5 Installation	25

5.1 Requirements for Installation	25
5.1.1 Requirements for Installation Location	25
5.1.2 Tools & Additional Accessories (not included in the scope of delivery)	26
5.1.3 Safety Gear & Required Personnel	26
5.2 Pre-installation Checking	27
5.3 Floor Installation	28
6 Electrical Connection	31
6.1 Functional Area Overview	31
6.2 Connection Diagram	32
6.2.1 Single Tower	32
6.2.2 Multiple Towers	33
6.3 Connecting the Grounding Conductor	34
6.4 Data Cable Connection	35
6.4.1 Data Cable Connection to the Inverter	35
6.4.2 Data Cable Connection to the Parallel Battery System	38
6.5 DC Connection	40
6.6 BYD Smart WiFi/LAN Module Installation	43
6.6.1 Internet Connection of Smart WiFi/LAN Module	44
6.6.2 LED Status and Key Operation of Smart WiFi/LAN Module	45
7 Commissioning	46
7.1 Switch on the Battery System	46
7.2 Configuration of Battery System	47
7.3 Switch on and Commission the Inverter	47
7.3.1 On-grid Applications	47
7.3.2 Off-grid Applications	48
8 Operation	49
8.1 Switch on the Battery System	49
8.1.1 On-grid Applications	49
8.1.2 Off-grid Applications	50
8.2 Switch off the Battery System	51
8.3 Safety Design	52
8.4 Protective Devices	52
9 Disassembly	53
10 Capacity Expansion	54
11 Troubleshooting	55
11.1 LED Failure Indication	55
11.2 Service Guide	55

12 Storage	56
13 Maintenance and Replacement	57
14 Disposal of Battery Module	58
15 Technical Parameters	59
16 Contact Information	64
Appendix Connection Options with Inverters	65

1 Information on this Document

Disclaimer

When installing, operating, and maintaining the equipment, read this manual first and follow all safety precautions in the equipment and manual.

BYD shall not be liable for any of the following circumstances.

- Do not operate under the conditions described in this manual.
- The installation and use environment does not comply with relevant international, national or regional standards.
- Unauthorized disassembly, alteration of the product or modification of the software code.
- Not following the safety instructions and precautions in the product and manual.
- Damage caused by abnormal natural environment (force majeure, such as earthquake, fire, wind, flood, mudslide, etc.).
- Losses due to customer transportation.
- Damage due to storage conditions not meeting the requirements of this manual.
- Hardware or data damage due to negligence, mishandling, or intentional damage by the customer.
- System damage caused by third parties or customers, including damage caused by improper transportation and installation that does not meet the requirements of this manual, and damage caused by adjustment, alteration, or removal of identification marks that do not meet the requirements of this manual.

* Reverse engineering, decompilation, disassembly, adaptation, implantation, or other derivative operations of the device software are prohibited. It is forbidden to study the internal implementation of the device, obtain the source code of the device software and steal intellectual property rights in any way. It is forbidden to disclose any performance test results of the equipment software.

1.1 Validity

This document is valid for the Battery-Box HVS+ 5.1, HVS+ 7.7, HVS+ 10.2, HVS+ 12.8, and HVM+ 8.3, HVM+ 11.0, HVM+ 13.8, HVM+ 16.6, HVM+ 19.3, HVM+ 22.1.

1.2 Target Groups

The instructions in this document may only be performed by qualified personnel with the following skills:

- Knowledge of how batteries work and are operated.
- Knowledge of how an inverter works and is operated.
- Knowledge of, and adherence to the locally applicable connection requirements, standards, and directives.
- Knowledge of, and adherence to this document and the associated system documentation, including all safety instructions.
- Trained in dealing with the hazards associated with the installation and operation of electrical equipment and batteries.
- Trained in the installation and commissioning of electrical equipment.
- Failure to do so will void any manufacturer's warranty, guarantee, or liability unless you can prove that the damage was not due to non-compliance.

1.3 Content and Structure of this Document

This document contains safety information and instructions, scope of delivery, battery system overview, installation, electrical connection, commissioning, operation, decommissioning, expansion, troubleshooting, maintenance and storage, battery system disposal, technical parameters and contact information. Read this document before performing any actions on the battery system.

1.4 Loading and Unloading Requirements

Batteries need to be handled in accordance with local laws, regulations and industry standards. Improper loading and unloading can result in shorting or damage to the battery, which can lead to leakage, rupture, explosion, or fire.

1.5 Transport Requirements

- Before shipment, the battery must be checked to ensure that it is intact and free from

unusual odors, smoke, fire, etc. Otherwise, shipment is prohibited.

- Packing must be secure. The product must be handled with care during transportation, and moisture-proof measures shall be taken. Considering the influence of external environment (such as temperature, transportation, storage, etc.), the specifications and parameters shall be subject to the date of manufacture.
- The following conditions must be prohibited during transportation: direct contact with rain, snow or immersion in water; falling or mechanical shock; inverted or tilted.

1.6 Declaration of Conformity

The battery system described in this document comply with applicable local directives. The certificate is available in the Downloads area of the www.bydenergy.com.

1.7 Warning Level

The following levels of warning messages may appear when handling the battery-system.

DANGER

Indicates a hazardous situation that, if not avoided, will result in death or serious injury.

WARNING

Indicates a hazardous situation which, if not avoided, could result in death or serious injury.

CAUTION

Indicates a hazardous situation which, if not avoided, could result in minor or moderate injury.

NOTICE

Indicates a situation that could result in property damage if not avoided.

1.8 Documentation Symbols

QUALIFIED PERSON

Describe activities performed by qualified personnel only.

1.9 Abbreviations and Definitions of Terms

No.	Designation	Explanation
1	Battery system	BYD Battery-Box HVS+ & HVM+
2	BCU	Battery Control Unit
3	BIC	Battery Information Collector
4	BMS	Battery Management System
6	BYD	BYD Lithium Battery Co., Ltd.
7	SOC	State of Charge
8	Smart WIFI/LAN Module	For detailed operation, please refer to the Quick Guide of the Smart WIFI/LAN Module

2 Security

Disclaimer

BYD shall not be liable for any functional failure, component damage, personal safety accident or property loss caused by the following reasons:

- The customer fails to charge the battery in time, resulting in loss of battery capacity or other irreversible damage.
- Falling, leaking or other damage caused by improper handling or connection.
- The user does not set the battery operation management parameters correctly.
- The customer or third party changes the battery usage scenario without consulting BYD.
- Mix the batteries provided by BYD with other batteries, including but not limited to: mixing with batteries of other brands, mixing with batteries of different rated capacities, etc.
- The working environment or external power supply parameters can not meet the requirements of the normal working environment, causing direct damage to the battery.
- The customer has not properly maintained the battery in accordance with the owner's manual.
- Out of warranty batteries.
- Battery damage due to the use of an inverter other than the Battery-Box HVS+&HVM+ Compatible Inverter List.
- Do not use accessories with recommended specifications.

2.1 Intended Use

Battery-Box HVS+&HVM+ work with photovoltaic systems for residential use. It is a high-voltage lithium-ion battery storage system with a control module that can operate in on-grid, off-grid, and backup modes via compatible inverter.

The battery system can be connected to the Internet and firmware updates via Smart WiFi/LAN Module.

The battery system can only be used as a fixed device.

The battery system is suitable for indoor and outdoor use under the conditions described in Section 5.1.

Battery system can only be used with the compatible inverters. A list of these inverters (BYD Battery-Box HVB&HVM+&HVS+ Compatible Inverter List) can be found in the www.bydenergy.com.

The battery system is not suitable for:

- Powering life-sustaining medical equipment, and location near medical equipment.
- Train, elevator and other control equipment may cause personal injury.
- Computer systems of social and public importance.
- Equipment similar to that described above.

Alterations, such as alterations or modifications, to the battery are not permitted unless written permission is obtained from BYD. Unauthorized changes will invalidate warranty and warranty claims.

BYD shall not be liable for any damage caused by such changes. The type label should always be attached to the battery system.

2.2 Important Safety Instructions

The battery system are designed and tested to meet international safety requirements. However, to prevent personal injury and property damage and to ensure long-term operation of the battery system, please read this section carefully and always observe all safety information.

2.2.1 Battery Module Leakage

If the battery module leaks electrolyte, avoid contact with the leaking liquid or gas. Electrolyte is corrosive and may cause skin irritation and chemical burns on contact. If you come in contact with leaking material, perform the following steps:

Accidental inhalation: Evacuate the contaminated area and seek medical attention immediately.

Eye exposure: Rinse eyes with running water for 15 minutes and seek immediate medical attention.

Skin contact: Wash the affected area thoroughly with soap and water and get medical help immediately.

Ingestion: Induce vomiting and seek medical help immediately.

2.2.2 Firefighting Measures

When the battery module is put into a fire, the battery module may catch fire. In the event of a fire, make sure there is an ABC or CO₂ fire extinguisher nearby. Do not use water to extinguish the fire.

Firefighters need to wear full protective clothing and self-contained breathing apparatus when fighting fires.

2.2.3 Battery Modules Handling and Storage Guide

The battery module and its components shall be protected from damage during transportation and handling.

- Do not hit, pull, or step on the battery module.
- Do not insert extraneous objects into any part of the battery module.
- Do not place the battery module in a fire.
- Do not immerse the battery module in water or seawater.
- Do not handle strong oxidizing agents.
- Do not short-circuit the battery module.
- The battery module cannot be stored at high temperatures ($\geq 50^{\circ}\text{C}$).
- The battery module cannot be stored directly in the sun.
- The battery module cannot be stored in a high humidity environment.
- Do not use the battery modules if they are defective, or appears cracked, broken or otherwise damaged, or fail to operate.
- Do not attempt to open, disassemble, repair, tamper with, or modify the battery modules. The battery modules are not user-serviceable.
- Do not use cleaning solvents to clean the battery modules.

2.2.4 Warning of Electric Shock



Danger to life due to electric shock when live components or power cables are touched

The power cables connected to an inverter may be live. Touching live power cables results in death or serious injury due to electric shock.

- Disconnect the battery system and inverter from the voltage source and make sure that they cannot be reconnected before operating the equipment.
- Do not touch non-insulated parts or cables.
- Do not remove the terminal block with the connected power cable from the slot under load.
- Wear appropriate personal protective equipment when performing all work on the battery system.
- Comply with all safety information from the inverter manufacturer.

2.2.5 Warning of Overvoltage



Danger to life due to electric shock in case of overvoltages and if surge protection is missing

Overvoltages (e.g. in the event of a flash of lightning) can be further conducted into the building and to other connected devices in the same network via the network cables or other data cables if there is no surge protection. Touching live parts and cables results in death or lethal injuries due to electric shock.

- Ensure that all devices and inverters in the same network are integrated into the existing surge protection.
- When laying network cables or other data cables outdoors, it must be ensured that a suitable surge protection device is provided at the transition point of the cable from the outdoor battery system or inverter to the interior of the building.

2.2.6 Caution of Weight

CAUTION

Risk of injury due to weight of the battery module

Injuries may result if the battery module is lifted incorrectly or dropped while being transported or installed.

- Carefully transport and lift the battery module. Consider the weight of the battery module.
- Wear appropriate personal protective equipment when performing all work on the battery system.

2.2.7 Notice of Property Damage

NOTICE

Damage to the BCU due to sand, dust and moisture ingress

Sand, dust and moisture penetration can damage the BCU and impair its functionality.

- Only open the BCU if the humidity is within the thresholds and the environment is free of sand and dust.

NOTICE

Damage to the battery system due to under voltages

- If the battery system does not start at all, please contact BYD's local after-sales service team within 48 hours. Otherwise, the battery may be permanently damaged.

3 Scope of Delivery

3.1 BCU and Base Package

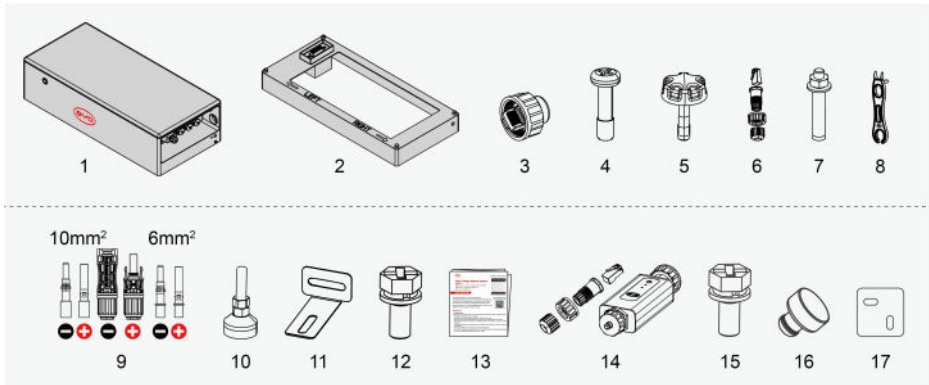

NO.	Quantity	Designation
1	1	BCU
2	1	Base
3	1	Terminal resistor
4	2	Screw M4*14 for Main Switch (Outdoor)
5	2	Knob screw for Main Switch (Indoor)
6	2	Communication terminal for two or three battery systems in parallel
7	2	Expansion screw M8 for fixing Hanger1 to wall
8	1	Connector special tool for Power cable connector
9	2	Power cable connectors for BCU
10	4	Adjustable feet for Base
11	2	Hanger1 for BCU
12	2	Screw M5*16 for fixing Hanger1
13	1	Quick Start Guide
14	1	Smart WiFi/ LAN Module
15	2	Screw M5*16 for fixing Hanger2
16	2	Rubber plug
17	2	Hanger2 for fixing BCU and battery module together (THESE ARE ESSENTIAL!)

3.2 Battery Module Package

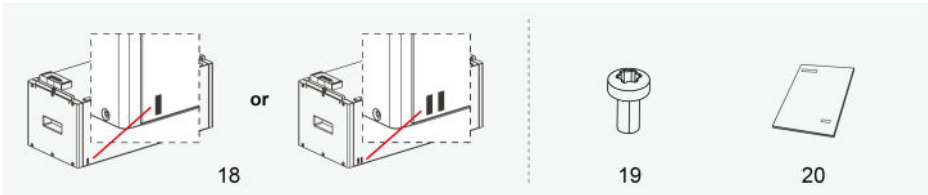

NO.	Quantity	Designation
18	1	HVS+ Module or HVM+ Module
19	2	Screw M5*10 for fixing battery modules together
20	2	Attached document (MSDS, EU declaration of conformity)



***There are two types of battery modules, HVS+ and HVM+. The HVS+ module has one stripe printed on it, and the HVM+ module has two stripes.**

4 Battery System Overview

4.1 Structure Dimension Drawing

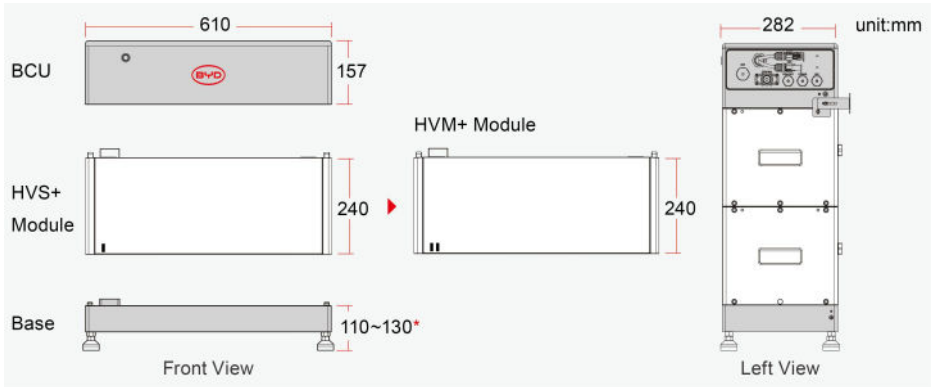

*The four feet of the base support adjustment within a height range of 110-130mm to adapt to possible tilts of the ground.

4.2 Battery System Description

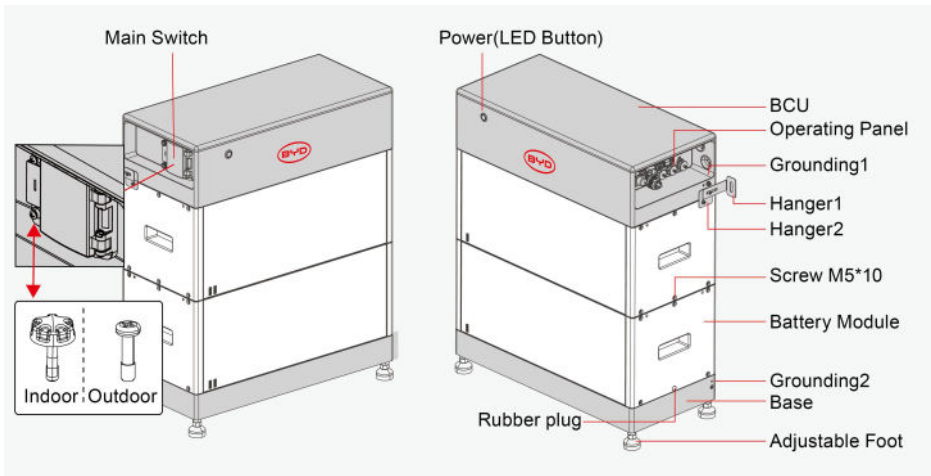

Two to five HVS+ battery modules or three to eight HVM+ battery modules could be installed in one tower. **DIFFERENT BATTERY MODULES CANNOT BE INSTALLED IN ONE TOWER.**

4.3 Battery System Scalability

The HVS+ battery system cannot be connected with the HVM+ battery system in parallel.

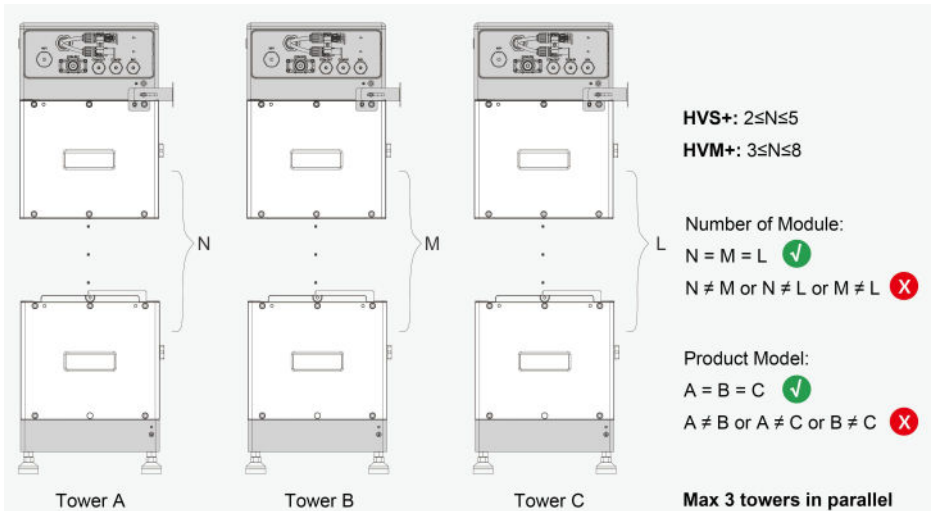

! Only one type of battery module can be used in the same tower!

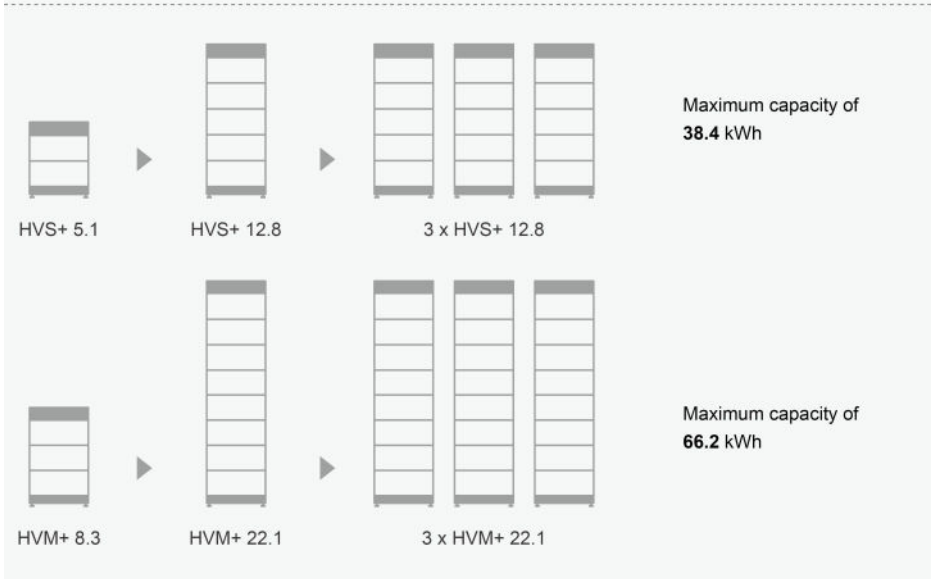

4.4 Interface

BYD Energy

BYD Energy is an app for Android and iOS system devices which can be downloaded from Google Play or App Store. Through the APP, you can realize intelligent battery management, including remote data monitoring, firmware upgrade and troubleshooting.

- **Android users:** Search for **"BYD Energy"** on Google Play or scan Android QR code to download and install.
- **iPhone users :** Search for **"BYD Energy"** in the App Store or scan iOS QR code to download and install.



Android



iOS

Configuration steps:



The battery system doesn't have a wireless communication function. Through the USB, the battery system supports the expansion of connection with the Smart WiFi/LAN Module to implement the wireless function, and the Smart WiFi/ LAN Module had obtained individual cyber security certification in accordance with EN 18031 series.

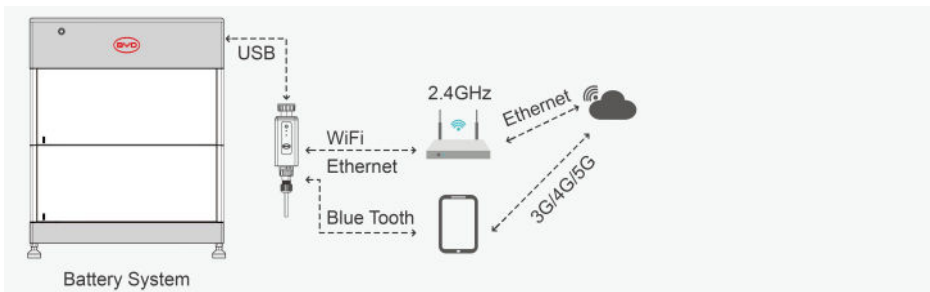













For detailed configuration steps, please refer to the App user manual

Website: www.bydenery.com

Scan the QR code to obtain the corresponding App video manual. ▶



4.5 Symbols

Symbol	Explanation
	<p>Observe the documents</p> <p>Observe all documents supplied with the system.</p>
	<p>Separate collection symbol</p> <p>Do not dispose of used batteries with other waste. Instead, collect and recycle them separately in accordance with Regulation (EU) 2023/1542.</p>
	<p>Separate collection symbol (WEEE)</p> <p>Do not dispose of the system together with the household waste but in accordance with the disposal regulations for electronic waste applicable at the installation site.</p>
	<p>CE marking</p> <p>The system complies with the requirements of the applicable EU directives.</p>
	<p>RCM (Regulatory Compliance Mark)</p> <p>The system complies with the brief guide to electrical equipment approvals in Australia.</p>
	<p>UKCA marking</p> <p>The product complies with the regulations of the applicable laws of England, Wales and Scotland.</p>
	<p>Keep the battery modules away from open flame or ignition sources.</p>
	<p>Beware of electrical voltage.</p>
	<p>Beware of a danger zone</p> <p>This symbol indicates that the system must be additionally grounded if additional grounding or equipotential bonding is required at the installation site.</p>
	<p>Keep the battery modules away from children.</p>
	<p>The product has been tested and certified by TUV Rheinland.</p>
	<p>Grounding conductor</p> <p>This symbol indicates the position for connecting a grounding conductor.</p>



This side up.



Handle with care.



Keep dry.

4.6 Labels





4.6.1 BCU Labels

BCU Nameplate	Warning Label	Contact Label																																																							
<p>Rechargeable Li-Ion Battery System Battery Box</p> <table border="1"> <thead> <tr> <th>Capacity</th> <th>Usable Energy</th> <th>Nominal Voltage</th> <th>Dimensions</th> <th>Weight</th> </tr> </thead> <tbody> <tr> <td>10kWh</td> <td>10.5kWh</td> <td>370V</td> <td>100-110-210</td> <td>100kg</td> </tr> <tr> <td>20kWh</td> <td>21.0kWh</td> <td>370V</td> <td>100-110-210</td> <td>100kg</td> </tr> <tr> <td>30kWh</td> <td>31.5kWh</td> <td>370V</td> <td>100-110-210</td> <td>100kg</td> </tr> <tr> <td>40kWh</td> <td>42.0kWh</td> <td>370V</td> <td>100-110-210</td> <td>100kg</td> </tr> <tr> <td>50kWh</td> <td>52.5kWh</td> <td>370V</td> <td>100-110-210</td> <td>100kg</td> </tr> <tr> <td>60kWh</td> <td>63.0kWh</td> <td>370V</td> <td>100-110-210</td> <td>100kg</td> </tr> <tr> <td>70kWh</td> <td>73.5kWh</td> <td>370V</td> <td>100-110-210</td> <td>100kg</td> </tr> <tr> <td>80kWh</td> <td>84.0kWh</td> <td>370V</td> <td>100-110-210</td> <td>100kg</td> </tr> <tr> <td>90kWh</td> <td>94.5kWh</td> <td>370V</td> <td>100-110-210</td> <td>100kg</td> </tr> <tr> <td>100kWh</td> <td>105.0kWh</td> <td>370V</td> <td>100-110-210</td> <td>100kg</td> </tr> </tbody> </table> <p>Chemistry: LiFePO₄ Nominal Voltage: 370V Max. Charge Current: 100A Max. Discharge Current: 100A Max. Charge Voltage: 3.7V Max. Discharge Voltage: 3.2V Operating Temperature: -20°C to 55°C Storage Temperature: -20°C to 55°C IP Rating: IP54 Protection Class: Overvoltage Category II Manufacturer: BYD Auto Co., Ltd. Address: Shenzhen, BYD Auto Co., Ltd. Korea Branch: Seoul, South Korea, 152-080 USA Branch: Fremont, CA, USA, 94538 Website: www.bydenergy.com</p> <p>UK CA CE UK CA CE</p> <p>MADE IN CHINA</p>	Capacity	Usable Energy	Nominal Voltage	Dimensions	Weight	10kWh	10.5kWh	370V	100-110-210	100kg	20kWh	21.0kWh	370V	100-110-210	100kg	30kWh	31.5kWh	370V	100-110-210	100kg	40kWh	42.0kWh	370V	100-110-210	100kg	50kWh	52.5kWh	370V	100-110-210	100kg	60kWh	63.0kWh	370V	100-110-210	100kg	70kWh	73.5kWh	370V	100-110-210	100kg	80kWh	84.0kWh	370V	100-110-210	100kg	90kWh	94.5kWh	370V	100-110-210	100kg	100kWh	105.0kWh	370V	100-110-210	100kg	<p>WARNING</p> <ol style="list-style-type: none"> For the transportation of this product, it is recommended to use the transportation container provided by the manufacturer. Any damage to the container during transportation may affect the safety of the product. Please contact the manufacturer's customer service department. Do not place any flammable objects or liquids on the battery pack. If a liquid spillage occurs, it may cause a fire or explosion. If a fire occurs, please use a fire extinguisher to extinguish it. If a fire occurs, please use a fire extinguisher to extinguish it. Do not short-circuit the battery terminals. Do not use a metal object to touch the terminals. Do not use a metal object to touch the terminals. Do not use the battery pack in a high-temperature environment. Do not use the battery pack in a high-temperature environment. <p>NOTICE</p> <p>All batteries should be used within their rated period of time. If the battery is used for a long time, it will be damaged. Please refer to the battery pack user manual for more details. Please refer to the battery pack user manual for more details.</p>	<p>Contact</p> <p>BYD Energy Storage Power Ltd. BYD Energy Storage Power Ltd. Head Office: 1111 3005 8888</p> <p>Europe: BYD Energy Storage BYD Energy Storage Ltd. Telephone: +44 (0)207 607 5588 +44(0)207 509595 (UK) +49 (0) 208 22 27 125 +86 (0) 21 3005 8888</p> <p>BYD Global Service: service@bydenergy.com</p> <p>Service policy is subject to BYD's product warranty.</p> <p>For more details, please refer to BYD Product Warranty. Registered Trade Name: BYD Energy Storage Address: Shenzhen, China, 518000, Support Factory, Ltd.</p>
Capacity	Usable Energy	Nominal Voltage	Dimensions	Weight																																																					
10kWh	10.5kWh	370V	100-110-210	100kg																																																					
20kWh	21.0kWh	370V	100-110-210	100kg																																																					
30kWh	31.5kWh	370V	100-110-210	100kg																																																					
40kWh	42.0kWh	370V	100-110-210	100kg																																																					
50kWh	52.5kWh	370V	100-110-210	100kg																																																					
60kWh	63.0kWh	370V	100-110-210	100kg																																																					
70kWh	73.5kWh	370V	100-110-210	100kg																																																					
80kWh	84.0kWh	370V	100-110-210	100kg																																																					
90kWh	94.5kWh	370V	100-110-210	100kg																																																					
100kWh	105.0kWh	370V	100-110-210	100kg																																																					

4.6.2 Battery Module Labels

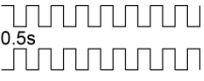
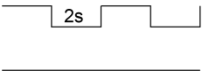
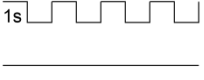
HVS+ Module Nameplate	HVM+ Module Nameplate	High Voltage Warning																																																																																																														
<p>Rechargeable Li-Ion Battery Battery Box HVS+ Model</p> <table border="1"> <thead> <tr> <th>Capacity</th> <th>Usable Energy</th> <th>Nominal Voltage</th> <th>Dimensions</th> <th>Weight</th> </tr> </thead> <tbody> <tr> <td>10kWh</td> <td>10.5kWh</td> <td>370V</td> <td>100-110-210</td> <td>100kg</td> </tr> <tr> <td>20kWh</td> <td>21.0kWh</td> <td>370V</td> <td>100-110-210</td> <td>100kg</td> </tr> <tr> <td>30kWh</td> <td>31.5kWh</td> <td>370V</td> <td>100-110-210</td> <td>100kg</td> </tr> <tr> <td>40kWh</td> <td>42.0kWh</td> <td>370V</td> <td>100-110-210</td> <td>100kg</td> </tr> <tr> <td>50kWh</td> <td>52.5kWh</td> <td>370V</td> <td>100-110-210</td> <td>100kg</td> </tr> <tr> <td>60kWh</td> <td>63.0kWh</td> <td>370V</td> <td>100-110-210</td> <td>100kg</td> </tr> <tr> <td>70kWh</td> <td>73.5kWh</td> <td>370V</td> <td>100-110-210</td> <td>100kg</td> </tr> <tr> <td>80kWh</td> <td>84.0kWh</td> <td>370V</td> <td>100-110-210</td> <td>100kg</td> </tr> <tr> <td>90kWh</td> <td>94.5kWh</td> <td>370V</td> <td>100-110-210</td> <td>100kg</td> </tr> <tr> <td>100kWh</td> <td>105.0kWh</td> <td>370V</td> <td>100-110-210</td> <td>100kg</td> </tr> </tbody> </table> <p>Chemistry: LiFePO₄ Nominal Voltage: 370V Max. Charge Current: 100A Max. Discharge Current: 100A Max. Charge Voltage: 3.7V Max. Discharge Voltage: 3.2V Operating Temperature: -20°C to 55°C Storage Temperature: -20°C to 55°C IP Rating: IP54 Protection Class: Overvoltage Category II Manufacturer: BYD Auto Co., Ltd. Address: Shenzhen, BYD Auto Co., Ltd. Korea Branch: Seoul, South Korea, 152-080 USA Branch: Fremont, CA, USA, 94538 Website: www.bydenergy.com</p> <p>UK CA CE UK CA CE</p> <p>MADE IN CHINA</p>	Capacity	Usable Energy	Nominal Voltage	Dimensions	Weight	10kWh	10.5kWh	370V	100-110-210	100kg	20kWh	21.0kWh	370V	100-110-210	100kg	30kWh	31.5kWh	370V	100-110-210	100kg	40kWh	42.0kWh	370V	100-110-210	100kg	50kWh	52.5kWh	370V	100-110-210	100kg	60kWh	63.0kWh	370V	100-110-210	100kg	70kWh	73.5kWh	370V	100-110-210	100kg	80kWh	84.0kWh	370V	100-110-210	100kg	90kWh	94.5kWh	370V	100-110-210	100kg	100kWh	105.0kWh	370V	100-110-210	100kg	<p>Rechargeable Li-Ion Battery Battery Box HVM+ Model</p> <table border="1"> <thead> <tr> <th>Capacity</th> <th>Usable Energy</th> <th>Nominal Voltage</th> <th>Dimensions</th> <th>Weight</th> </tr> </thead> <tbody> <tr> <td>10kWh</td> <td>10.5kWh</td> <td>370V</td> <td>100-110-210</td> <td>100kg</td> </tr> <tr> <td>20kWh</td> <td>21.0kWh</td> <td>370V</td> <td>100-110-210</td> <td>100kg</td> </tr> <tr> <td>30kWh</td> <td>31.5kWh</td> <td>370V</td> <td>100-110-210</td> <td>100kg</td> </tr> <tr> <td>40kWh</td> <td>42.0kWh</td> <td>370V</td> <td>100-110-210</td> <td>100kg</td> </tr> <tr> <td>50kWh</td> <td>52.5kWh</td> <td>370V</td> <td>100-110-210</td> <td>100kg</td> </tr> <tr> <td>60kWh</td> <td>63.0kWh</td> <td>370V</td> <td>100-110-210</td> <td>100kg</td> </tr> <tr> <td>70kWh</td> <td>73.5kWh</td> <td>370V</td> <td>100-110-210</td> <td>100kg</td> </tr> <tr> <td>80kWh</td> <td>84.0kWh</td> <td>370V</td> <td>100-110-210</td> <td>100kg</td> </tr> <tr> <td>90kWh</td> <td>94.5kWh</td> <td>370V</td> <td>100-110-210</td> <td>100kg</td> </tr> <tr> <td>100kWh</td> <td>105.0kWh</td> <td>370V</td> <td>100-110-210</td> <td>100kg</td> </tr> </tbody> </table> <p>Chemistry: LiFePO₄ Nominal Voltage: 370V Max. Charge Current: 100A Max. Discharge Current: 100A Max. Charge Voltage: 3.7V Max. Discharge Voltage: 3.2V Operating Temperature: -20°C to 55°C Storage Temperature: -20°C to 55°C IP Rating: IP54 Protection Class: Overvoltage Category II Manufacturer: BYD Auto Co., Ltd. Address: Shenzhen, BYD Auto Co., Ltd. Korea Branch: Seoul, South Korea, 152-080 USA Branch: Fremont, CA, USA, 94538 Website: www.bydenergy.com</p> <p>UK CA CE UK CA CE</p> <p>MADE IN CHINA</p>	Capacity	Usable Energy	Nominal Voltage	Dimensions	Weight	10kWh	10.5kWh	370V	100-110-210	100kg	20kWh	21.0kWh	370V	100-110-210	100kg	30kWh	31.5kWh	370V	100-110-210	100kg	40kWh	42.0kWh	370V	100-110-210	100kg	50kWh	52.5kWh	370V	100-110-210	100kg	60kWh	63.0kWh	370V	100-110-210	100kg	70kWh	73.5kWh	370V	100-110-210	100kg	80kWh	84.0kWh	370V	100-110-210	100kg	90kWh	94.5kWh	370V	100-110-210	100kg	100kWh	105.0kWh	370V	100-110-210	100kg	<p>DANGER High Voltage</p>
Capacity	Usable Energy	Nominal Voltage	Dimensions	Weight																																																																																																												
10kWh	10.5kWh	370V	100-110-210	100kg																																																																																																												
20kWh	21.0kWh	370V	100-110-210	100kg																																																																																																												
30kWh	31.5kWh	370V	100-110-210	100kg																																																																																																												
40kWh	42.0kWh	370V	100-110-210	100kg																																																																																																												
50kWh	52.5kWh	370V	100-110-210	100kg																																																																																																												
60kWh	63.0kWh	370V	100-110-210	100kg																																																																																																												
70kWh	73.5kWh	370V	100-110-210	100kg																																																																																																												
80kWh	84.0kWh	370V	100-110-210	100kg																																																																																																												
90kWh	94.5kWh	370V	100-110-210	100kg																																																																																																												
100kWh	105.0kWh	370V	100-110-210	100kg																																																																																																												
Capacity	Usable Energy	Nominal Voltage	Dimensions	Weight																																																																																																												
10kWh	10.5kWh	370V	100-110-210	100kg																																																																																																												
20kWh	21.0kWh	370V	100-110-210	100kg																																																																																																												
30kWh	31.5kWh	370V	100-110-210	100kg																																																																																																												
40kWh	42.0kWh	370V	100-110-210	100kg																																																																																																												
50kWh	52.5kWh	370V	100-110-210	100kg																																																																																																												
60kWh	63.0kWh	370V	100-110-210	100kg																																																																																																												
70kWh	73.5kWh	370V	100-110-210	100kg																																																																																																												
80kWh	84.0kWh	370V	100-110-210	100kg																																																																																																												
90kWh	94.5kWh	370V	100-110-210	100kg																																																																																																												
100kWh	105.0kWh	370V	100-110-210	100kg																																																																																																												

4.7 LED Signals

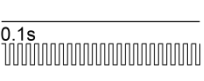
Indicator	Status	Description
Flashing white and blue alternatively	White <input type="radio"/> ON <input type="radio"/> OFF Blue <input checked="" type="radio"/> ON <input type="radio"/> OFF	 <p>0.5s</p> <p>The battery system is initiating</p>
Flashing white slowly	White <input type="radio"/> ON <input type="radio"/> OFF Blue <input checked="" type="radio"/> ON <input type="radio"/> OFF	 <p>2s</p> <p>The battery system is charging</p>
Flashing white	White <input type="radio"/> ON <input type="radio"/> OFF Blue <input checked="" type="radio"/> ON <input type="radio"/> OFF	 <p>1s</p> <p>The battery system is discharging</p>
Constant white	White <input type="radio"/> ON <input type="radio"/> OFF Blue <input checked="" type="radio"/> ON <input type="radio"/> OFF	 <p>Idle (the battery system is either charging nor discharging).</p>
Flashing white fairly quickly	White <input type="radio"/> ON <input type="radio"/> OFF Blue <input checked="" type="radio"/> ON <input type="radio"/> OFF	 <p>0.25s</p> <p>Black start function</p>
Flashing white quickly	White <input type="radio"/> ON <input type="radio"/> OFF Blue <input checked="" type="radio"/> ON <input type="radio"/> OFF	 <p>0.1s</p> <p>The battery system is updating software</p>
Flashing blue quickly	White <input type="radio"/> ON <input type="radio"/> OFF Blue <input checked="" type="radio"/> ON <input type="radio"/> OFF	 <p>0.1s</p> <p>Exit system</p>



The specific logic of LED lights can be found in the Service Guideline and Checklist.

5 Installation

5.1 Requirements for Installation





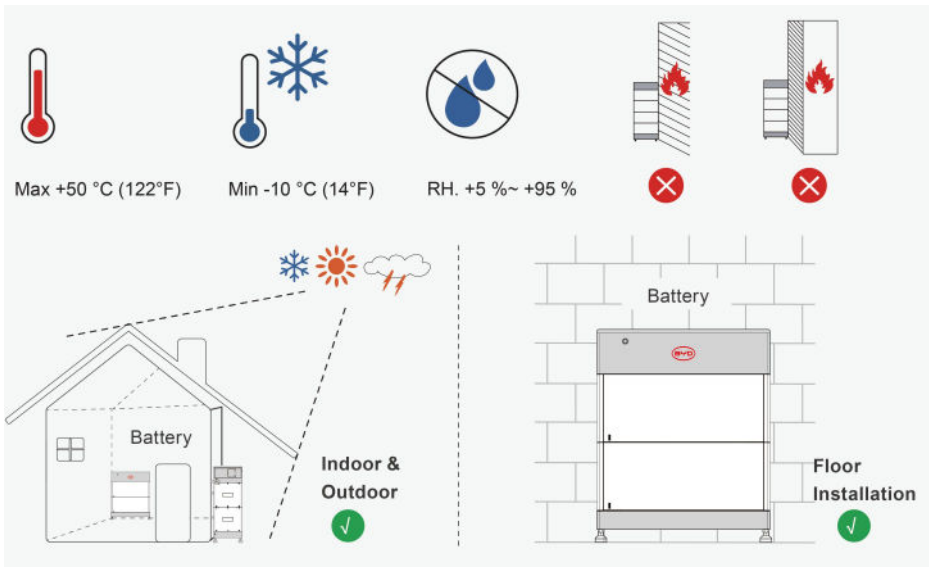

















5.1.1 Requirements for Installation Location

- a) A solid support surface must be available (e.g., concrete or masonry).
- b) The installation location must be inaccessible to children.
- c) The installation location must be suitable for the weight and dimensions of the battery system.
- d) The installation location must not be exposed to direct solar irradiation, rainwater and snow.
- e) The horizontal level of the installation site shall be above the highest water level of that area in history and at least 300 mm above the ground. The installation site must not be located in a low-lying land.
- f) The installation location must not be close to the heat sources.
- g) The altitude of the installation location should be less than 3000 m.
- h) The ambient temperature should be between -10 °C and +50 °C.
- i) The ambient humidity should be between 5-95% (non-condensing).



5.1.2 Tools & Additional Accessories (not included in the scope of delivery)

You may need to use the tools in the following table during the installation process.

						
(Ø:10mm, D:55mm)	(M10, M8)	(YQK-70)	(+M5 +M3)	(-M2.5)	(M5-T25)	
Drill	Wrench	Hydraulic crimping plier	Screwdriver			
						
Knife	Gradienter	Tape measure	Rubber mallet	Heat gun	Network wire clamp	
			 Recommended use batteries HVM+ ≥ 6			
Pen	Wire stripper					
	Current input > 30A 8AWG / 10mm ² Ø:6.5-7.5mm Current input ≤ 30A 10AWG / 6mm ² Ø:5.2-6mm					
DC Cable		Data Cable	OT Terminal	PE Cable		
 ≥750V		Cat.5e Ø:5-6mm	10mm ² -M5	8AWG / 10mm ²		
						
Heat Shrink Tubing						
Ø:8-10mm						

 The Cat.7 data cable is required for connection to the Kostal inverter.

5.1.3 Safety Gear & Required Personnel

The battery system requires two qualified installers to operate. Wear the following safety gear when dealing with the battery system.

			
Insulated gloves	Safety shoes	Goggles	2 qualified installers

5.2 Pre-installation Checking

QUALIFIED PERSON

DANGER

Danger to life from electric shock due to live power cables or connectors at the battery system

The power cables connected to the battery system may be live. Touching the power conductors or the live components leads to lethal electric shocks.

- Do not touch non-insulated cable ends.

CAUTION

Risk of injury due to weight of the battery module

Injuries may result if the battery module is lifted incorrectly or dropped while being transported or installed.

- Carefully transport and lift the battery module. Consider the weight of the battery module.
- Wear appropriate personal protective equipment when performing all work on the battery module.work on the battery system.

Inspection before installation:

Product packaging: Before removing the energy storage packaging, inspect the packaging for visible damage, such as holes, cracks, or other internal signs of possible damage, and check the energy storage model.If there is any abnormal packaging or the energy storage model does not match, do not open it and contact your dealer as soon as possible.

Inspection of deliverables: After unpacking the energy storage overpack, check the deliverables for completeness and for any visible external damage.If any items are missing or if there is any damage, contact your dealer.

5.3 Floor Installation

Procedure:

1. Take out the battery module, Base, accessories, and BCU from the corresponding packing box.
2. Install the adjustable feet to the base.

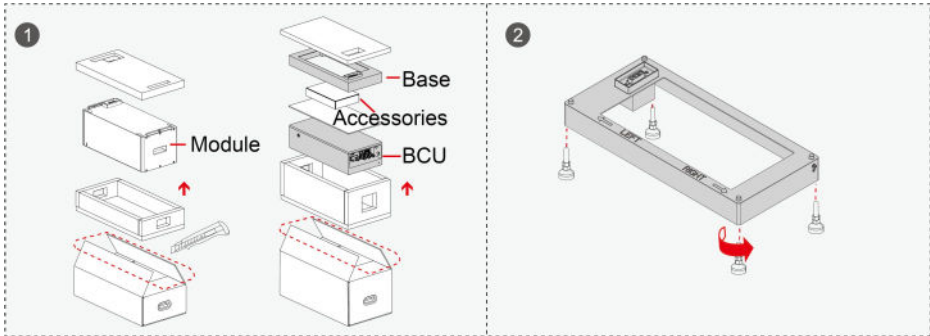

3. Put the installed base along the wall following the **LEFT** and **RIGHT** markings on the base, and keep a distance of 35~65mm between the wall and the base.

4. Adjust the feet with a wrench to ensure that the battery remains horizontal (**Tilt is not allowed!**).

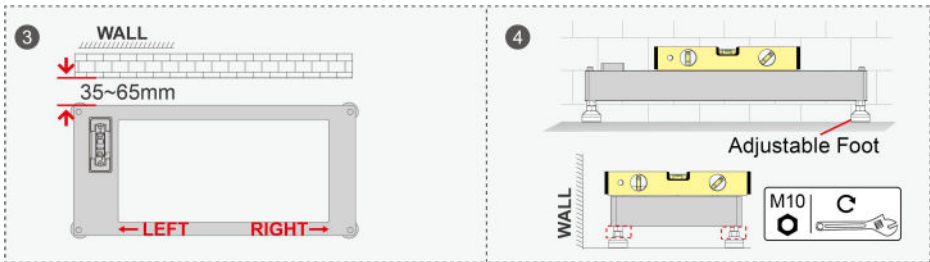

5. Stack the battery modules one by one on the base, and stack the BCU on the top.



Pay attention to the direction of the module. The blind-mate connectors on the battery module, the base and the BCU should be on the same side.

There is electricity in the blind socket, please do not touch it !

6. Screw the hanger2 with the first battery module and mark the drilling positions for hanger1 and hanger2 to the wall. Please ensure that no power cables or other supply lines (e.g., gas or water) are laid in the wall, which could be damaged when drilling holes.

7. Move the BCU and the first battery module aside and then drill holes at the marked locations.



Please cover the blind socket to avoid falling dust !

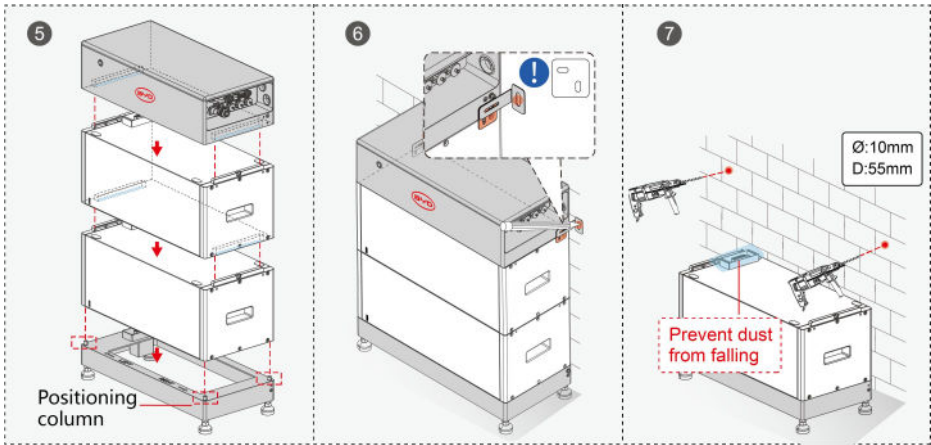

8. Hammer the two expansion screws into the holes with a rubber mallet, loosen the screw part of the expansion screw and remove it.

9. Move the battery module and the BCU back to the initial position, and then fasten the hanger2 to the BCU and the adjacent battery module by M5*16 screws with a Phillips screwdriver (torque: 4-5 Nm), then fix the hanger1 to the wall using a wrench (torque: 4-5 Nm).

10. Install the rubber plugs on both sides of the bottom battery module, tighten the screws (M5*10) connecting the other battery modules with a T-25 torx bits (torque: 4-5 Nm).

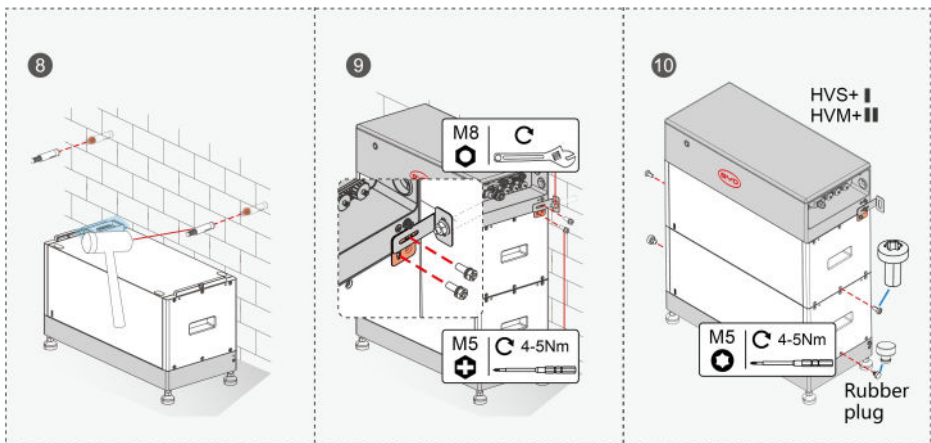

11. Mark the product type on the BCU nameplate.

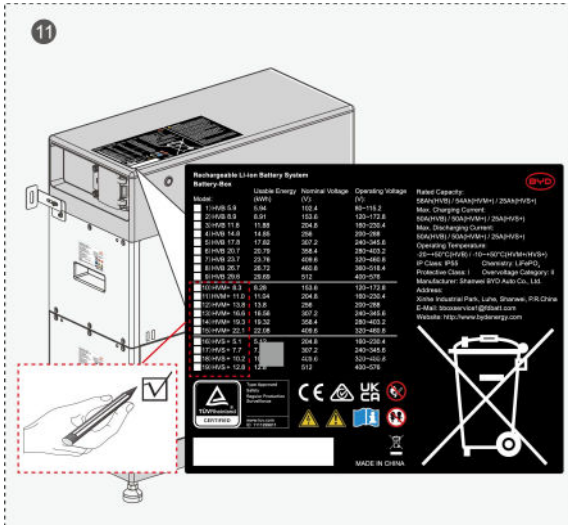

Model	Number of HVM+ Modules
HVM+ 8.3	3
HVM+ 11.0	4
HVM+ 13.8	5
HVM+ 16.6	6
HVM+ 19.3	7
HVM+ 22.1	8

Model	Number of HVS+ Modules
HVS+ 5.1	2
HVS+ 7.7	3
HVS+ 10.2	4
HVS+ 12.8	5

NOTICE

Damage to the battery system due to under voltages

- If the battery is installed, it should be set into operation within a month, or checked regularly, otherwise there might be damage to the batteries.

6 Electrical Connection

6.1 Functional Area Overview

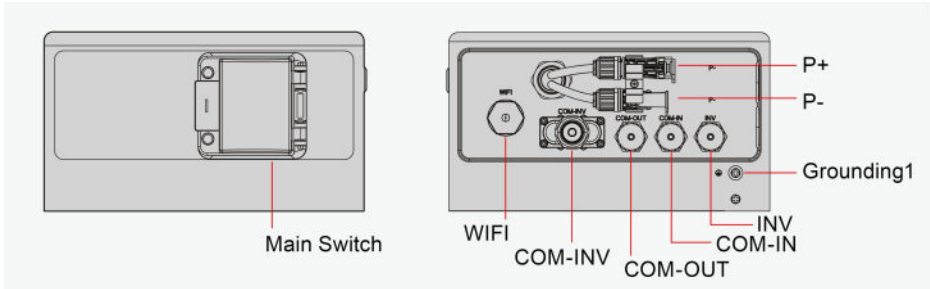

Terms	Description
WIFI	Port for smart WIFI/LAN module.
COM - INV	Port for data cable in, for inverter connection.
COM - OUT	Port for data cable out, for battery parallel connection.
COM - IN	Port for data cable in, for battery parallel connection.
INV	Port for data cable in, for inverter connection.
Grounding	Grounding connection.
P+	Connect to positive terminal of inverter.
P-	Connect to negative terminal of inverter.
MAIN Switch	Power on/power off.

6.2 Connection Diagram

6.2.1 Single Tower

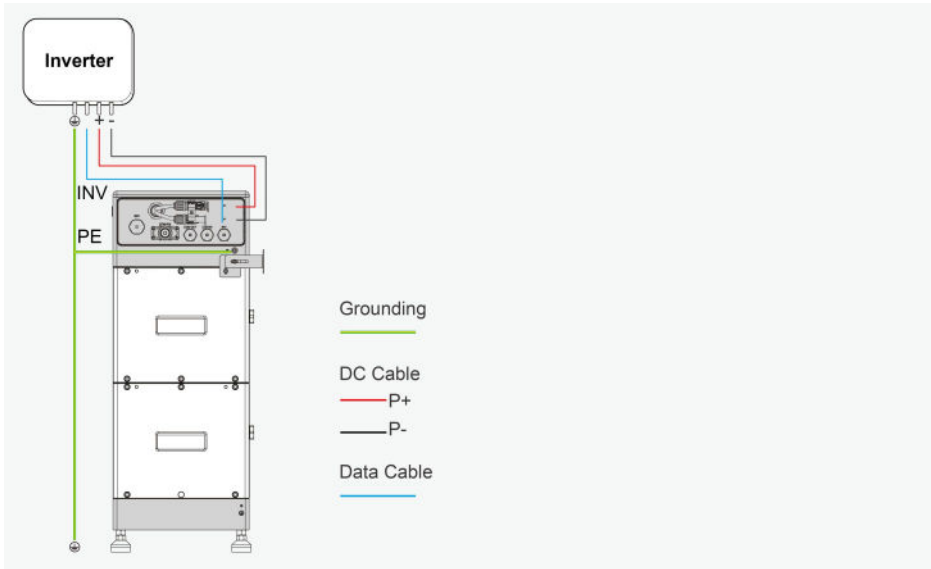

6.2.2 Multiple Towers

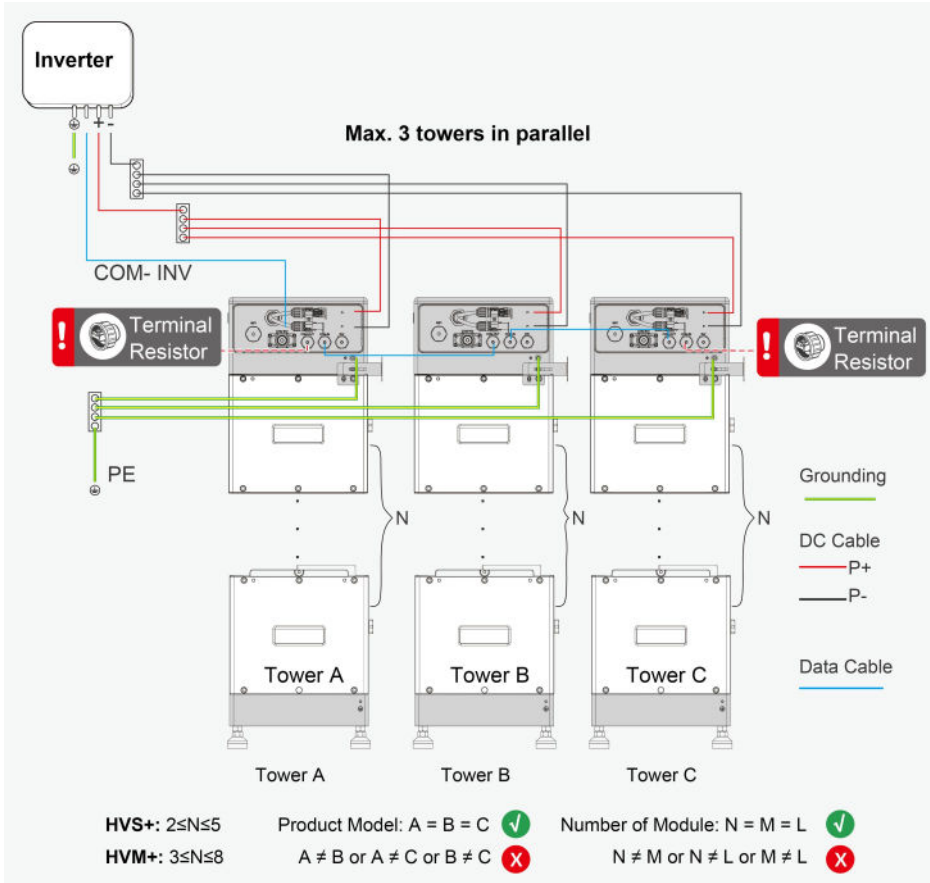

Only one type of battery module can be used in the same tower!

When two or three battery systems work in parallel, terminal resistors must be installed: plug the terminal resistor into the “OUT” port of the master module and the “IN” port of the last slave module. Two (2) or more BCU require two (2) terminal resistors.



The terminal resistor is not compulsory for single tower.

The length of the power cables from each tower to the combiner box should be the same.

It is recommended that the power cable length between battery towers and the inverter should be less than 3 meters.

6.3 Connecting the Grounding Conductor

⚠ QUALIFIED PERSON

When installing, the grounding wire must be installed first; when removing the equipment, the grounding wire must be removed last.

Additional required installation materials (not included in the scope of delivery): PE with terminals.

PE and terminal requirements:

- OT-Terminal: 10 mm²-M5
- The cross section of the earth terminal must comply with the applicable local standards and directives.
- PE cable cross-section: 10 mm²
- PE material: copper

Note: If the maximum current of the connected inverter is no more than 40 A, a PE cable with 6 mm² cross-section area is also acceptable.

Procedure:

1. Strip the PE cable by 10-15 mm.
2. Get the cable through the heat shrink tubing and connect the OT terminal to the core cable.
3. Crimp the OT terminal and the core cable with a crimping pliers.
4. Get the heat shrink tubing back to cover the connection part of the cable and the OT terminal. Blow the heat shrink tubing with heat gun.
5. Switch off the main switch of BCU. Tighten the PE cable on the BCU by a M5*16 screw with a Phillips screwdriver (torque: 3-4 Nm).

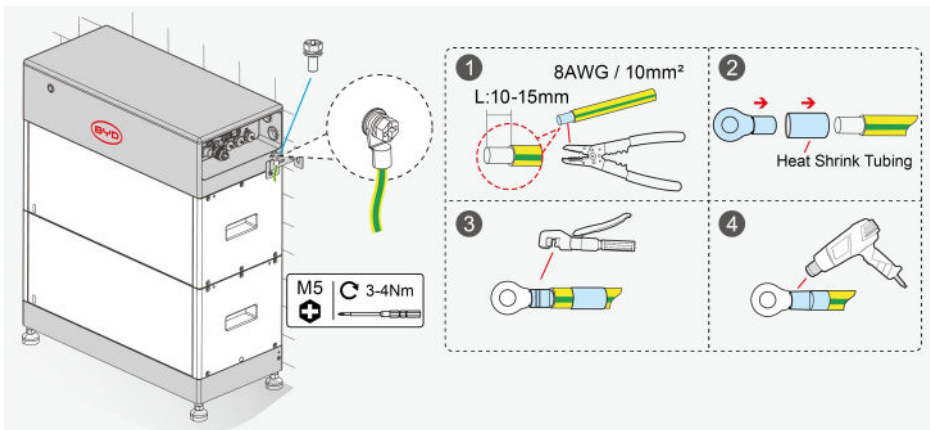

6.4 Data Cable Connection

6.4.1 Data Cable Connection to the Inverter



There are two communication modes for connecting HVS+ and HVM+ to the inverter, one of which can be selected for connection.

Option A: RJ45

Option B: 8-Pin terminal

Read the inverter port name on the battery system and the inverter manual to decide whether to modify the data cable. The connection diagram with different inverters could be read in the Appendix. The pin designation of "INV" port on BCU could be read below.

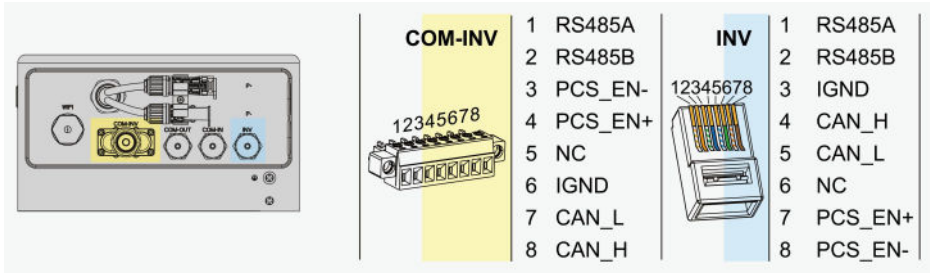

Do not crimp the unused pins when making the communication cable between the battery and the inverter.

Additional required installation materials (not included in the scope of delivery): one data cable.

Data cable requirements:



The length and quality of the cable affect the quality of the signal.

- Cable category: Cat.5, Cat.5e or higher
- Plug type: Cat.5, Cat.5e or higher metal shield RJ45
- Shield: Yes
- UV protection for outdoor use
- Maximum cable length: 3 m (recommend)

Option A: RJ45**Procedure:**

1. Unscrew the waterproof covered on the INV port.
2. Connect the RJ45 connector:
 - A: Trim the data cable according to the pin designation of "INV" port and also that of the corresponding port at the inverter.
 - B: Get the end of the data cable without the RJ45 plug through the screw nut and seal nut of the communication connector according to the image below. (If the data cable has two RJ45 plugs, cut the cable to make sure at least one end has no RJ45 plug.)
 - C: Insert the RJ45 connector into the INV port of the BCU and tighten the waterproof cover.
3. Insert the other end of the connector into the corresponding port of the inverter.

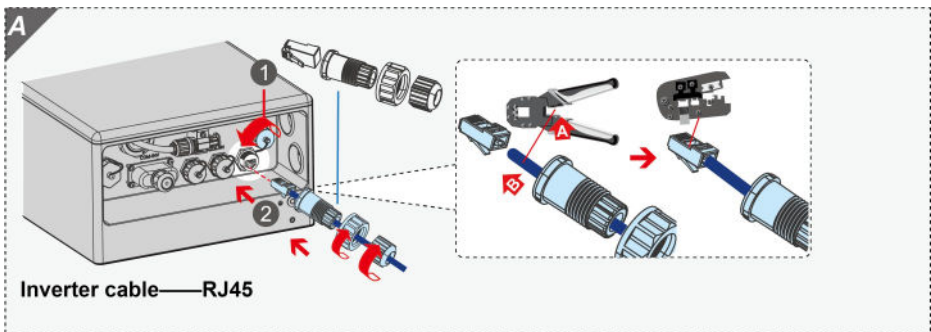
**Option B: 8-Pin terminal****Procedure:**

1. Loosen the screws of the external waterproof cover and quick-connect terminal on the COM-INV using a Phillips screwdriver and a Flathead screwdriver respectively according to the image below.
2. Connect the 8-Pin terminal:
 - A: Pass the data cable through the external waterproof cover.
 - B: Loosen the screws of the 8-Pin terminal with a Flathead screwdriver, and insert the harness into the corresponding terminal according to the pin designation of "COM-INV" port, and then tighten the screws.
 - C: Insert the wired 8-Pin terminal into the "COM-INV" port of the BCU and tighten the screws.

3. Screw the external waterproof cover with a Phillips screwdriver (torque: 1.2 Nm).
4. Tighten the screw nut and seal nut of the external waterproof cover in turn.
5. Insert the other end of the connector into the corresponding port of the inverter.

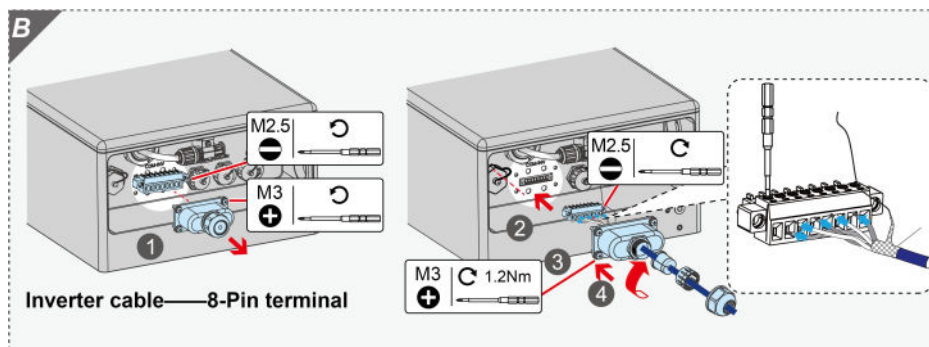

6.4.2 Data Cable Connection to the Parallel Battery System

This connection could only need to be made when two or three battery systems are connected in parallel.

The connection diagram of two battery towers could be read below.

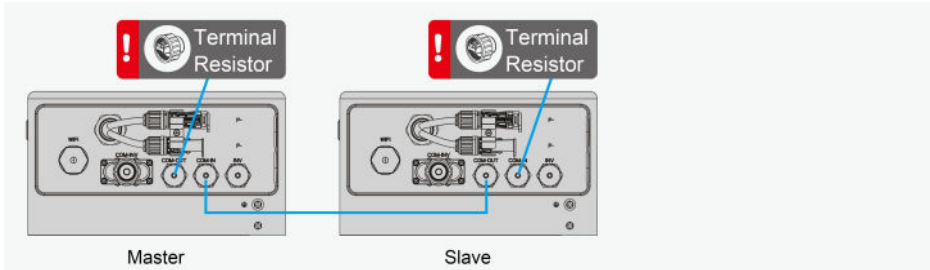

The connection diagram of three battery towers could be read below.

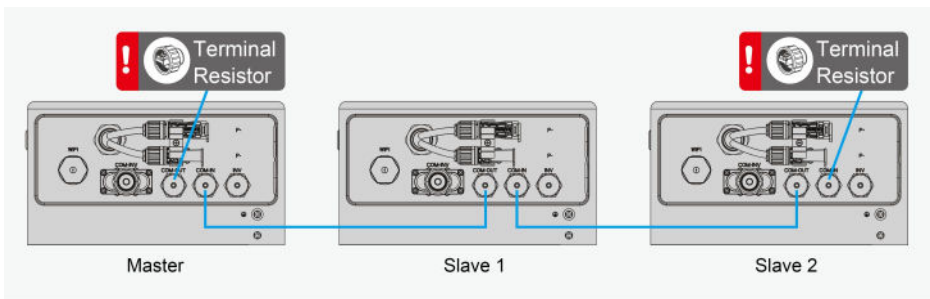

Additional required installation materials (not included in the scope of delivery): one or two data cables.

Data Cable Requirements:



The length and quality of the cable affect the quality of the signal.

- Cable category: Cat.5, Cat.5e or higher
- Plug type: Cat.5, Cat.5e or higher metal shield RJ45
- Shield: Yes
- UV protection for outdoor use
- Straight-through cable
- Maximum cable length between two towers: 3 m (recommend)

Procedure:

1. Remove the IN & OUT external waterproof cover.
2. Assemble the RJ45 connector according to the mentioned in section 6.4.1. Connect the "COM-IN" port of the master tower with the "COM-OUT" port of the first slave tower, the "COM-IN" port of the first slave tower with the "COM-OUT" port of the second slave tower (if any).
3. Connect the terminal resistor, plug the terminal resistor into the "OUT" port of the master module and the "IN" port of the last slave module.

* Data cable & terminal resistor are used for parallel connection

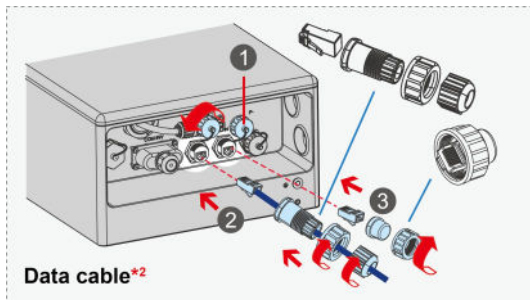

6.5 DC Connection

 **QUALIFIED PERSON**

 **DANGER**

Danger to life from electric shock due to live power cables or connectors at the battery system

The power cables connected to the battery system may be live. Touching the power conductors or the live components leads to lethal electric shocks.

- Do not touch non-insulated cable ends.

When two or three battery systems are connected, the length of the positive power cables should be approximately equal for all towers, and so are the negative power cables. A combiner box is required to combine these cables. Follow your local, state, provincial, federal, or national laws, regulations, and inverter manufacturer's instructions to select the appropriate combiner box.

Additional Installation Material Requirements(not included in the scope of delivery): two power cables per tower

Cable requirements:

- Conductor cross-section: 6 mm² (Current input ≤ 30A) or 10 mm² (Current input > 30A).
Select the correct option based on the application and the inverter manufacturer's requirements.
- Maximum cable length: 3 m (recommend)



The power cable must withstand a minimum voltage of 750V.

Procedure:

1. Use wire strippers to strip the insulation layer of the positive and negative cables to an appropriate length.
2. Put the insulation layer of the positive and negative cables into the corresponding metal terminals, and crimp them tightly with crimping pliers.
- 3~6. Insert the crimped positive and negative cables into the corresponding cable coupler, tighten the plastic nuts at the end of the insulating shell of the positive and negative connectors.

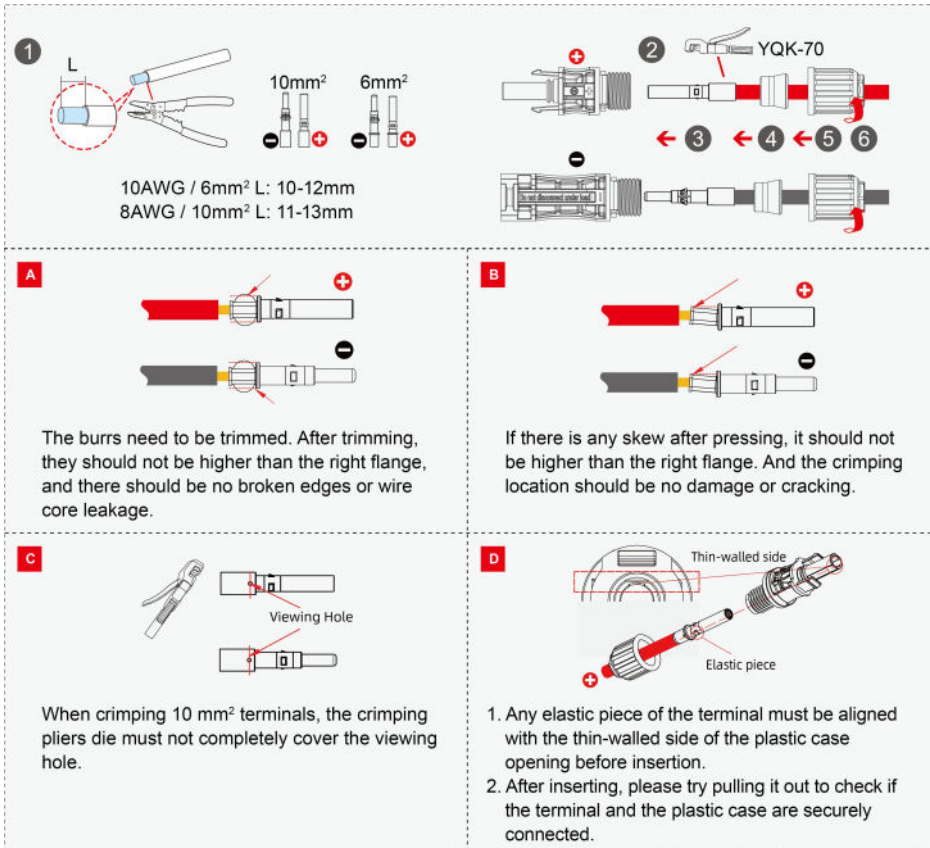

7. Loosen the iron sheets fixing the positive and negative poles of the power cable.

8-9. Remove the protection plugs of the positive and negative cable couplers on the BCU, and insert the corresponding wired cable couplers to the positive and negative poles.

10. Tighten the bracket fixing the positive and negative poles of the power cable (torque: 1.2 Nm).

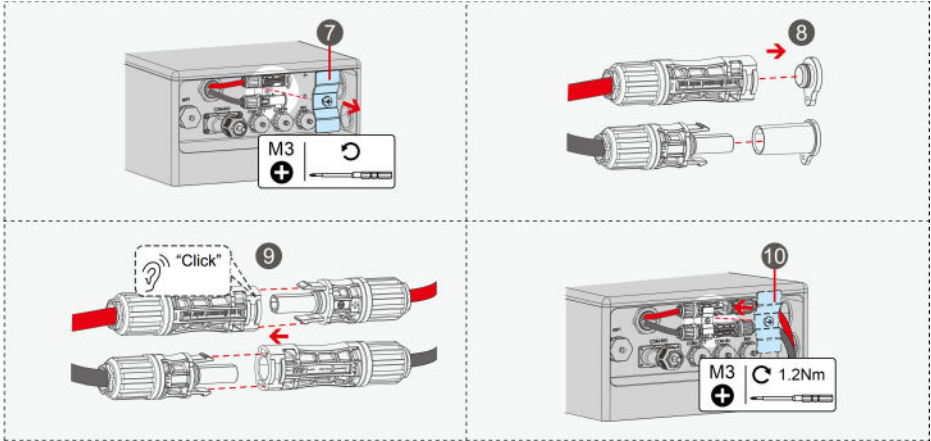

Outlet Direction

There are two outlet directions, one of which can be selected for connection:

Option E: Side cable exit

Option F: Rear cable exit

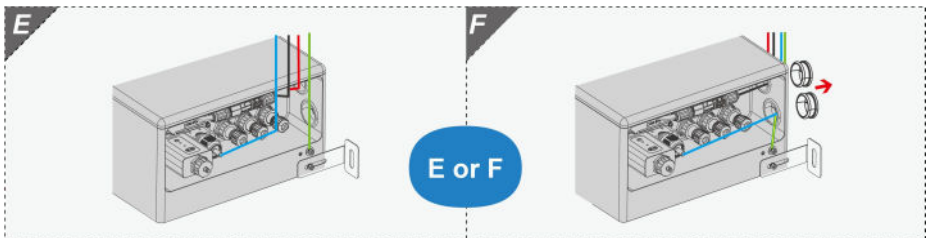

6.6 BYD Smart WIFI/LAN Module Installation

The battery system cannot connect to the Internet without the Smart WIFI/LAN Module. In this case, a RJ485-USB adapter is required for after-sales and debugging.

If two or three battery systems are operating in parallel simultaneously, the Smart WIFI/LAN Module only needs to be installed in the master battery system. In this case, it should be installed on the battery system that connected to the inverter via communication cables.

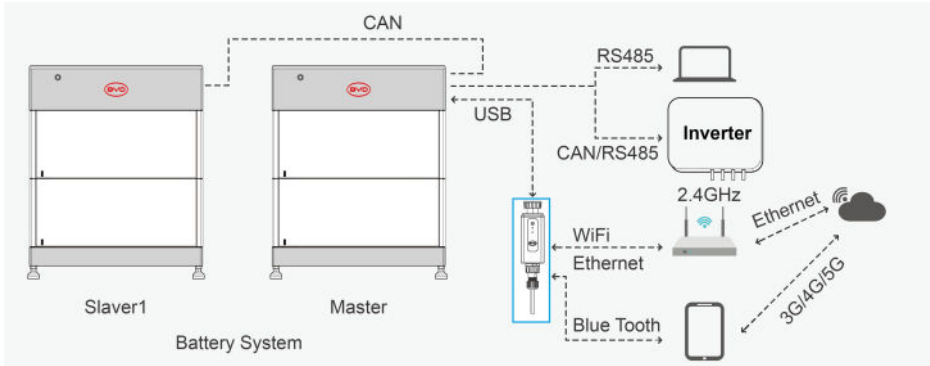

! QUALIFIED PERSON

! DANGER

Danger to life due to electric shock in case of overvoltages and if surge protection is missing

Overvoltages (e.g. in the event of a flash of lightning) can be further conducted into the building and to other connected devices in the same network via the network cables or other data cables if there is no surge protection. Touching live parts and cables results in death or lethal injuries due to electric shock.

- Ensure that all devices and inverters in the same network are integrated into the existing surge protection.
- When laying network cables or other data cables outdoors, it must be ensured that a suitable surge protection device is provided at the transition point of the cable from the outdoor battery system or inverter to the interior of the building.

We recommend that you install the Smart WIFI/LAN Module and complete the network configuration simultaneously when installing the battery system, to enable real-time monitoring of the battery's working status and ensure the battery operates in an optimal software environment.

Connection to the Internet is recommended, not compulsory.

6.6.1 Internet Connection of Smart WiFi/LAN Module

Connection Option

There are two modes for connecting HVS+ and HVM+ to the Internet, one of which can be selected for connection.

Option C: Wi-Fi

Option D: Ethernet

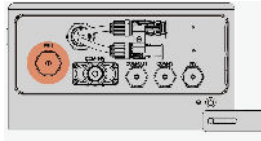

Option C: WIFI

Procedure:

1. Remove the external waterproof cover of WIFI port.
2. Insert the Smart WiFi/LAN Module. Network configuration must be performed via the BYD Energy app. Please refer to the section 7.2 for more details.

Option D: Ethernet

Procedure:

1. Unscrew the waterproof cap on the Smart WiFi/LAN Module.
2. Connect the network cable between the Smart WiFi/LAN Module and the router, and the green light of the Smart WiFi/LAN Module will be always on when the network has been connected successfully.

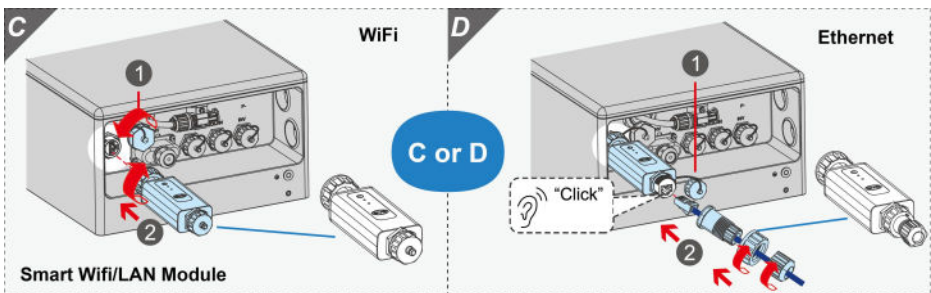







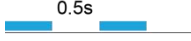

First of all, after connecting the Smart WiFi/LAN Module to the BCU, the indicator usually goes into the Waiting for Network Configuration state.

For the first connection, it is recommended to use the BYD Energy App on the phone to connect to the Smart WiFi/LAN Module via Bluetooth, and then connect to the network according to the App prompt.

Note: the Bluetooth connection between App and Smart WiFi/LAN Module can be realized regardless of the option C or D. Please refer to the section 7.2 for more details.

6.6.2 LED Status and Key Operation of Smart WiFi/LAN Module

The LED status of Smart WiFi/LAN Module are shown as follows:

Indicator	Frequency	Status	Description
Bluetooth 	On for 0.5s and then off for 0.5s		Blinking slowly: The Bluetooth is not connected.
	Steady on		Steady on: The Bluetooth connection is successful.
	On for 0.1s and then off for 0.1s		Blinking quickly: Bluetooth pairing mode.
Network 	On for 0.5s and then off for 0.5s		Blinking slowly: The Network is not connected.
	Steady on		Steady on: The Network connection is successful.
Bluetooth & Network 	From steady on to blinking quickly, after 3 seconds, blinking slowly		steady on >>> blinking quickly >>> blinking slowly: Bluetooth and Network restore factory settings

The key operations of Smart WiFi/LAN Module are shown as follows:

Operation	Description
Press and hold for more than 10 seconds	Restore factory settings
press and hold for more than 3 seconds	Re-enter the distribution network status after completing the distribution network setup
Press and hold for more than 3 seconds	Reset the Bluetooth at Single Bluetooth connection mode

7 Commissioning

7.1 Switch on the Battery System

⚠ QUALIFIED PERSON

Requirements:

- The power cable connection between the battery system and the inverter must be off.
- The inverter must be installed correctly.
- All cables must be correctly connected.
- The operation panel is well fixed.

Procedure:

1. Turn on the circuit breaker between the battery and the inverter (if any).
2. Push the main switch from "OFF" to "ON".
3. The LED starts blinking for a while (0.5 seconds white and 0.5 seconds blue alternating) and then changes to white, which means the battery system is ready to work.
4. If the battery system cannot be opened, please read Chapter 11 Troubleshooting in this manual or Service Guide and Checklist. **IF THE PROBLEM STILL CANNOT BE SOLVED, PLEASE CONTACT OUR LOCAL AFTER-SALE SERVICE TEAM WITHIN 48 HOURS.**

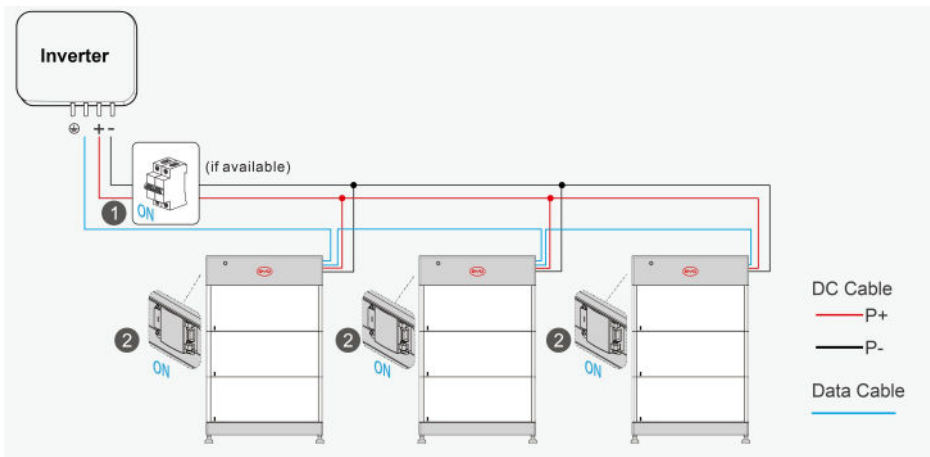

Max. short circuit current value: 2.56kA (HVM+) / 2.42kA (HVS+),
Short circuit duration: < 8ms

7.2 Configuration of Battery System

! QUALIFIED PERSON

Refer to the Inverter User Manual and **BYD Energy App Quick Operation Guide** for detail configuration steps.

7.3 Switch on and Commission the Inverter

! QUALIFIED PERSON

The procedure is different for on-grid and off-grid applications.

7.3.1 On-grid Applications

Procedure:

1. Install and connect the inverter according to the inverter manufacturer's instructions.
2. Set the DC disconnector of the inverter to the "ON".
3. Configure and debug the inverter according to the instructions of the inverter.

If the battery information can be read correctly on the inverter, it means that the connection is all right. If the LED is blinking blue, and/or some battery errors are displayed on the inverter, refer to Chapter 11 Troubleshooting in this manual and read the Service Guide and Checklist.

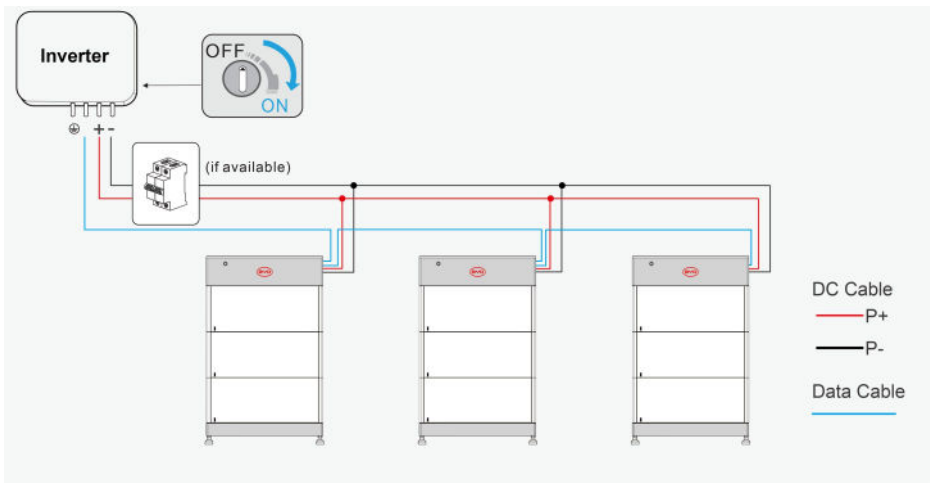

7.3.2 Off-grid Applications

Procedure:

1. Install and connect the inverter according to the inverter manufacturer's instructions.
2. Set the DC disconnecter of the inverter to the "ON".
3. **Black start:** press the LED button on the main system BCU for 3 seconds.
4. Configure and debug the inverter according to the instructions of the inverter.

If the battery information can be read correctly on the inverter, it means that the connection is all right. If the LED is blinking blue, and/or some battery errors are displayed on the inverter, refer to Chapter 11 Troubleshooting in this manual and read the Service Guide and Checklist.

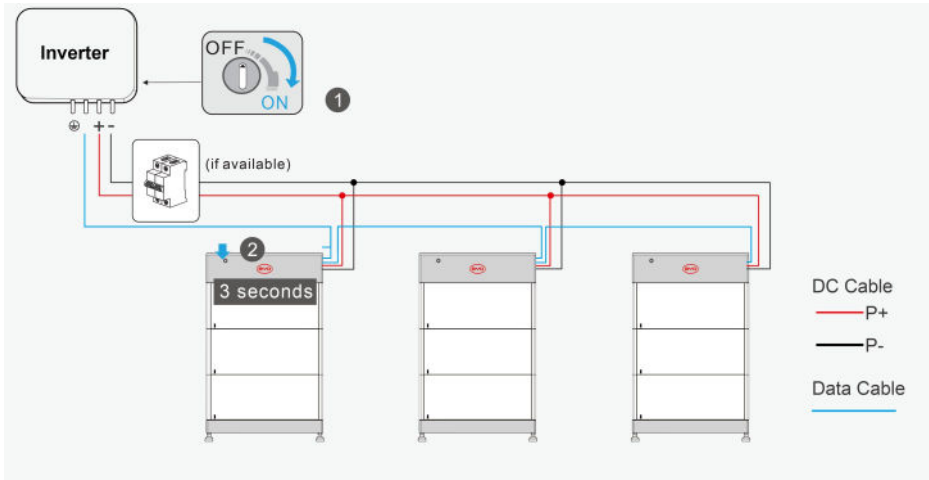

8 Operation

8.1 Switch on the Battery System

8.1.1 On-grid Applications

To ensure that the battery system works well with the inverter, follow the correct procedure to start them.

Procedure:

1. Switch on the circuit breaker between the inverter and the battery (if any).
2. Switch on the battery system(s).
3. Set the DC disconnector of the inverter to the "ON".

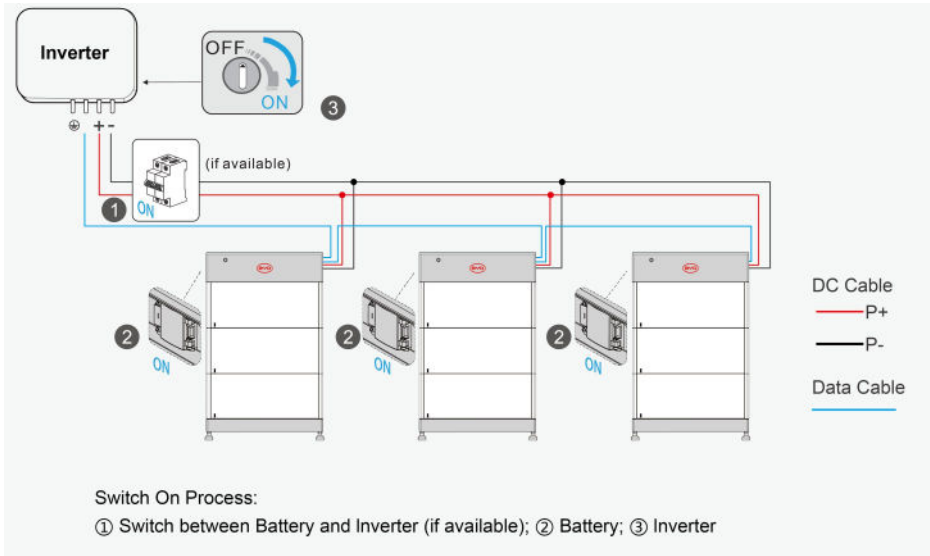

8.1.2 Off-grid Applications

To ensure that the battery system works well with the inverter, follow the correct procedure to start them.

Procedure:

1. Switch on the circuit breaker between the inverter and the battery (if any).
2. Switch on the battery system(s).
3. Set the DC disconnector of the inverter to the "ON".
4. **Black start:** Press the LED button of the main system for 3 seconds.

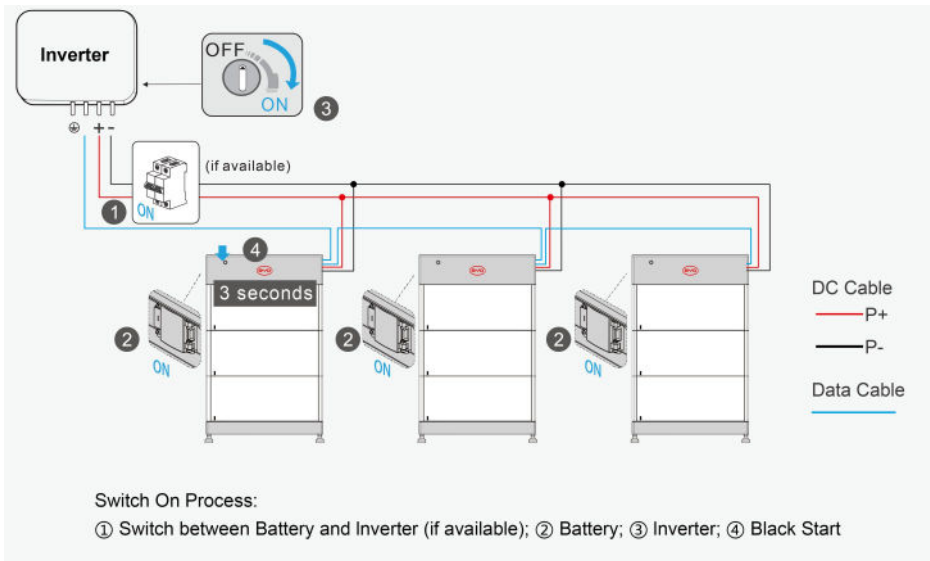

8.2 Switch off the Battery System

Procedure:

1. Set the DC disconnector of the inverter to the "OFF".
2. Turn off the battery: press the LED Button for 5 seconds on the BCU, but **NOT** to switch the main switch of BCU "OFF".
3. Switch off the circuit breaker between the battery and the inverter if there is any.

If two or three battery systems are connected in parallel, only the LED Button on the master system needs to be pressed. The slave system(s) will be turned off automatically.

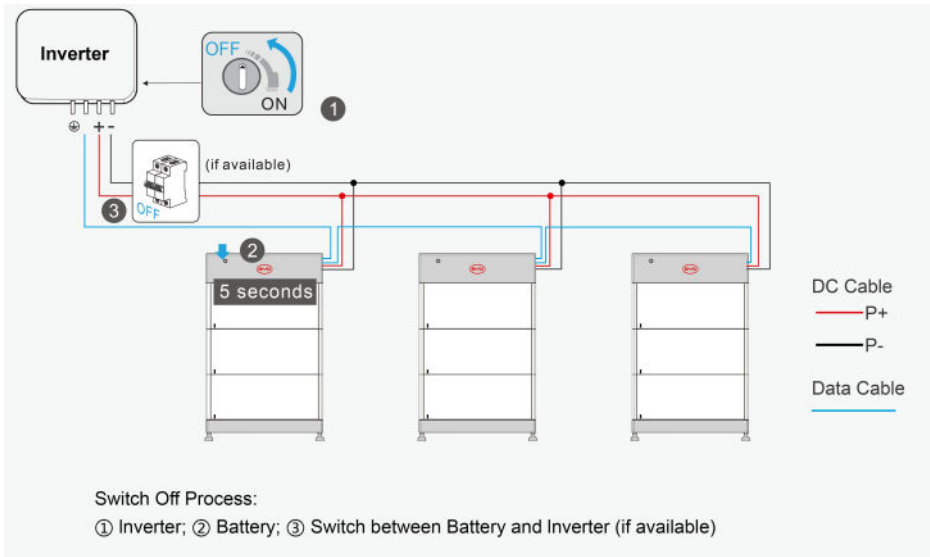

8.3 Safety Design

The system will switch off automatically, in one of these two cases:

1. If there is no communication with inverter, after 5 minutes, the blue indicator light of the BCU will enter flashing state at a frequency of 1s. The system will wait for the connection with the inverter to be re-established. After 23.5 hours, the system will enter the error, at same time the blue indicator light of the BCU will be on constantly and the system will be turned off automatically after 30 minutes.
2. If there is an error for 30 minutes, at which time the blue indicator light of the BCU will be on constantly and the system will be turned off automatically after 30 minutes.

8.4 Protective Devices

If the battery system configuration list is not met, the battery system can protect itself (shut down).

If external protection is required, follow local, state, provincial, federal, or national laws, regulations, and the inverter manufacturer's instructions.

9 Disassembly

QUALIFIED PERSON

DANGER

Danger to life from electric shock due to live power cables or connectors at the battery system

The power cables connected to the battery system may be live. Touching the DC conductors or the live components leads to lethal electric shocks.

- Do not touch non-insulated cable ends.

CAUTION

Risk of injury due to weight of the battery module

Injuries may result if the battery module is lifted incorrectly or dropped while being transported or installed.

- Transport and lift the battery module carefully. Take the weight of the battery module into account.
- Wear suitable personal protective equipment for all work on the battery system.

Procedure:

1. Switch off the inverter.
2. Turn off the battery system.
3. Switch off the circuit breaker (if any) between the inverter and the battery system.
4. Unplug all cables from the battery system.
5. Loosen all the screws between the battery module, BCU and the wall, take off the hangers, and then remove the BCU, battery modules and the base.

If the battery system is to be stored or shipped, pack the system. Use the original packaging or packaging that is suitable for the weight and dimensions of the system.

Dispose of the battery system in accordance with the locally applicable battery disposal regulations for electronic waste.

10 Capacity Expansion

Advice charge or discharge the existing system to an SOC of around 25~30%.

Note: New modules have a SOC of around 25~30%.

The battery system will automatically balance the SOC of difference battery modules to the same after multiple charge-discharge cycles. It depends on the actual charging and discharging conditions, which may take several days or even a month.

Procedure:

1. Switch off the inverter.
2. Turn off the battery system.
3. Switch off the circuit breaker (if any) between the inverter and the battery system.
4. Remove the BCU.
5. Stack the new module(s) on the top of the other battery modules.
6. Move the BCU back on the top of the new battery module, and install the hangers.
7. Turn on and configure the battery system.
8. Switch on the inverter.

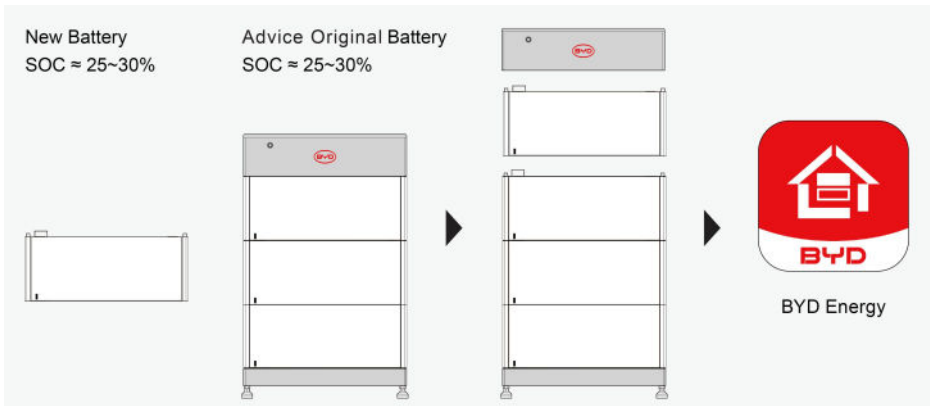



Please make sure the Original Battery isn't under forced charging(SOC>5%).

11 Troubleshooting

Please also see the BYD Battery-Box HVS+&HVM+ Service Guideline and Checklist for troubleshooting. The latest version is available at our website www.bydenery.com.

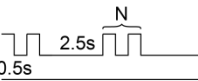
11.1 LED Failure Indication

Indicator	Status	Description
Constant blue	White <input type="radio"/> ON <input type="radio"/> OFF Blue <input checked="" type="radio"/> ON <input type="radio"/> OFF	 BCU failure
Constant blue and white light flashes a certain number of times	White <input type="radio"/> ON <input type="radio"/> OFF Blue <input checked="" type="radio"/> ON <input type="radio"/> OFF	 Flashing N times, represents the Nth battery module failure counting from top to bottom. HVS+: $1 \leq N \leq 5$; HVM+: $1 \leq N \leq 8$;
Flashing blue	White <input type="radio"/> ON <input type="radio"/> OFF Blue <input checked="" type="radio"/> ON <input type="radio"/> OFF	 The battery has entered a protective state
Flashing blue quickly	White <input type="radio"/> ON <input type="radio"/> OFF Blue <input checked="" type="radio"/> ON <input type="radio"/> OFF	 Exit System

11.2 Service Guide

In addition to the LED light, we can also get the fault information of the battery through the mobile phone application. Please refer to the latest Service Guide for detailed steps. Website: www.bydenery.com.

The battery module cannot be turned on/off. Check that the system has been built according to BYD BATTERY-BOX HVB&HVM+&HVS+ COMPATIBLE INVERTER LIST. If the problem still cannot be solved, please contact the local BYD after-sales service within 48 hours.

NOTICE

Battery module is damaged due to too low voltage.

- If the battery module does not start at all, please contact BYD's local after-sales service within 48 hours. Otherwise, the battery may be permanently damaged.

12 Storage

Cleaning

It is recommended that the battery system be cleaned periodically. If the enclosure is dirty, please use a soft, dry brush or a dust collector to remove the dust. Liquids such as solvents, abrasives, or corrosive liquids should not be used to clean the enclosure.

The battery module shall be stored in an environment with a temperature range from -10°C to $+50^{\circ}\text{C}$ and charged regularly according to the table below with no more than 0.5 C (C-rate is a measure of the rate at which a battery is charged and discharged relative to its maximum capacity) to the SOC of 30% after a long time of storage.

Storage temperature	Storage humidity	Storage time	SOC
Below -10°C	/	Not allowed	/
$-10\sim 25^{\circ}\text{C}$	5%~70%	≤ 12 months	$25\% \leq \text{SOC} \leq 60\%$
$25\sim 35^{\circ}\text{C}$	5%~70%	≤ 6 months	$25\% \leq \text{SOC} \leq 60\%$
$35\sim 50^{\circ}\text{C}$	5%~70%	≤ 3 months	$25\% \leq \text{SOC} \leq 60\%$
Above 50°C	/	Not allowed	/

NOTICE

Damage to the system due to under voltages.

- Charge the over-discharged system within seven days when the temperature is above.
- Charge the over-discharged system within fifteen days when the temperature is below 25°C .

13 Maintenance and Replacement

- Do not perform maintenance on the equipment unless you are familiar with the contents of this manual and have the proper tools and test equipment.
- Professional technicians and operators shall be fully trained and have knowledge of safe operation and maintenance of the equipment. They should take adequate precautions and personal protective equipment while operating.
- Before the equipment is repaired, the power must be cut off and the safety precautions in this manual and other relevant documents must be strictly observed.
- During maintenance, try to avoid irrelevant personnel entering the site.
- The unit cannot be powered up again until all faults have been resolved. Failure to do so may result in more problems or damage to the device.
- Do not open the cover without authorization, otherwise there is a risk of electric shock. Any faults caused by the above reasons are not covered by the warranty.
- Replace the battery with the same type.
- Immediately after completing maintenance, check to make sure no tools or other parts are left in the equipment.
- When the battery is idle for a long time, it must be stored and charged according to this manual.





14 Disposal of Battery Module

Battery modules must be disposed of in accordance with applicable local regulations for the disposal of electronic waste and used batteries.

- Do not dispose of the battery module with household waste.
- Avoid exposing the battery to heat or direct sunlight.
- Avoid exposing the battery to high humidity or corrosive environments.

For more information or to arrange a collection, please contact BYD Service Partner (see contact details at the bottom of this document).

15 Technical Parameters

				
PERFORMANCE	HVS+ 5.1	HVS+ 7.7	HVS+ 10.2	HVS+ 12.8
Battery Module	HVS+ (2.56 kWh, 102.4 V, 38.5 kg)			
Number of Modules	2	3	4	5
Usable Energy ^[1]	5.12 kWh	7.68 kWh	10.24 kWh	12.8 kWh
Max. Output Current ^[2]	25 A	25 A	25 A	25 A
Peak Output Current ^[2]	55 A, 15 s	55 A, 15 s	55 A, 15 s	55 A, 15 s
Nominal Voltage	204.8 V	307.2 V	409.6 V	512 V
Operating Voltage	160 - 230.4 V	240 - 345.6 V	320 - 460.8 V	400 - 576 V
Dimensions(H/W/D)	747 x 610 x 282mm	987 x 610 x 282mm	1227 x 610 x 282mm	1467 x 610 x 282mm
Weight	91.1 kg	129.6 kg	168.1 kg	206.6 kg
Battery Designation	IFpP21/174/120/[(1P32S)2S]M/- 10+50/90	IFpP21/174/120/[(1P32S)3S]M/- 10+50/90	IFpP21/174/120/[(1P32S)4S]M/- 10+50/90	IFpP21/174/120/[(1P32S)5S]M/- 10+50/90
Discharge Power at 20% SOC	4.9 kW	7.35 kW	9.8 kW	12.25 kW
Discharge Power at 80% SOC	5.1 kW	7.65 kW	10.2 kW	12.75 kW
Internal Resistance	≤260mΩ	≤390mΩ	≤520mΩ	≤650mΩ
Increase of Internal Resistance	≤15% after 10 years or 3650 cycles			
Expected life-time	The remaining capacity is above 60% after 3650 cycles or above 10 years using			
GENERAL DATA				
Operating Temperature	-10°C to +50°C			
Cell Technology	Lithium Iron Phosphate (LiFePO ₄)			
Communication	CAN / RS485			
IP Class	IP55			
Round-trip Efficiency	≥ 95%			

Installation Scene	Indoor / Outdoor Installation
Installation Mode	Floor Stand
Storage Humidity	5%~95%
Altitude	< 3000 m
Certification	VDE2510-50 / IEC62619 / CE / UKCA / UN38.3
Applications	ON Grid / ON Grid + Backup / OFF Grid
Warranty ^[3]	10 Years

[1] DC Usable Energy, Test conditions: 100% DOD, 0.2C charge & discharge at + 25°C. System Usable Energy may vary with different inverter brands.

[2] Power derating will occur between -10°C and +5°C.

[3] Conditions apply. Refer to BYD Battery-Box HVS+ Limited Warranty Letter.

NOTE

A: 2.56kWh is the initial capacity (designed) of the Energy Storage Module.

B: The actual capacity is affected by the external environment (such as temperature, transportation, and storage).



PERFORMANCE	HVM+ 8.3	HVM+ 11.0	HVM+ 13.8
Battery Module	HVM+ (2.76 kWh, 51.2 V, 41.4 kg)		
Number of Modules	3	4	5
Usable Energy ^[1]	8.28 kWh	11.04 kWh	13.80 kWh
Max Output Current ^[2]	50 A	50 A	50 A
Peak Output Current ^[2]	80 A, 15 s	80 A, 15 s	80 A, 15 s
Nominal Voltage	153.6 V	204.8 V	256 V
Operating Voltage	120 - 172.8 V	160 - 230.4 V	200 - 288 V
Dimensions(H/W/D)	987 x 610 x 282mm	1227 x 610 x 282mm	1467 x 610 x 282mm
Weight	138.3 kg	179.7 kg	221.1 kg
Battery Designation	IFpP47/174/122/[(1P16S) 3S]M/-10+50/90	IFpP47/174/122/[(1P16 S)4S]M/-10+50/90	IFpP47/174/122/[(1P16 S)5S]M/-10+50/90
Discharge Power at 20% SOC	7.38 kW	9.84 kW	12.3 kW
Discharge Power at 80% SOC	7.59 kW	10.12 kW	12.65 kW
Internal Resistance	≤105mΩ	≤140mΩ	≤175mΩ
Increase of Internal Resistance	15% after 10 years or 3650 cycles		
Expected life-time	The remaining capacity is above 60% after 3650 cycles or above 10 years using		



PERFORMANCE	HVM+ 16.6	HVM+ 19.3	HVM+ 22.1
Number of Modules	6	7	8
Usable Energy ^[1]	16.56 kWh	19.32 kWh	22.08 kWh
Max Output Current ^[2]	50 A	50 A	50 A
Peak Output Current ^[2]	80 A, 15 s	80 A, 15 s	80 A, 15 s
Nominal Voltage	307.2 V	358.4 V	409.6 V
Operating Voltage	240 - 345.6 V	280 - 403.2 V	320 - 460.8 V
Dimensions(H/W/D)	1707 x 610 x 282mm	1947 x 610 x 282mm	2187 x 610 x 282mm
Weight	262.5 kg	303.9 kg	345.3kg
Battery Designation	IFpP47/174/122/[(1P16 S)6S]M/-10+50/90	IFpP47/174/122/[(1P16 S)7S]M/-10+50/90	IFpP47/174/122/[(1P16 S)8S]M/-10+50/90
Discharge Power at 20% SOC	14.76 kW	17.22 kW	19.68 kW
Discharge Power at 80% SOC	15.18 kW	17.71 kW	20.24 kW
Internal Resistance	≤245mΩ	≤280mΩ	≤315mΩ
Increase of Internal Resistance	15% after 10 years or 3650 cycles		
Expected life-time	The remaining capacity is above 60% after 3650 cycles or above 10 years using		

GENERAL DATA

Operating Temperature	-10°C to +50°C
Cell Technology	Lithium Iron Phosphate (LiFePO ₄)
Communication	CAN / RS485
IP Class	IP55
Round-trip Efficiency	≥ 95%
Installation Scene	Indoor / Outdoor Installation
Installation Mode	Floor Stand

Storage Humidity	5%~95%
Altitude	< 3000 m
Certification	VDE2510-50 / IEC62619 / CE / UKCA / UN38.3
Applications	ON Grid / ON Grid + Backup / OFF Grid
Warranty ^[3]	10 Years

[1] DC Usable Energy, Test conditions: 100% DOD, 0.2C charge & discharge at + 25°C. System Usable Energy may vary with different inverter brands.

[2] Power derating will occur between -10°C and +5°C.

[3] Conditions apply. Refer to BYD Battery-Box HVM+ Limited Warranty Letter.

NOTE

A: 2.76kWh is the initial capacity (designed) of the Energy Storage Module.

B: The actual capacity is affected by the external environment (such as temperature, transportation, and storage).

16 Contact Information

BYD Global Service

Address: No.3009, BYD Road, Pingshan, Shenzhen, 5118118, P.R.China

Service Mailbox: bboxservice1@fdbatt.com

Website: www.bydenery.com

BYD Authorized Service Partner

EFT-Systems GmbH

Address: Bruchtannenstraße 28, 63801 Kleinostheim

Service Mailbox: service@eft-systems.de

Telephone: +49 9352 8523999, +44 (0) 2037695998(UK) ,+34 91 060 22 67(ES)

+39 02 87368364(IT)

Website: www.eft-systems.de

BYD Authorized Service Partner

ALPS Power Pty Ltd

Address:2/62 Belmore Rd North, Riverwood NSW 2210

Service Mailbox: service@alpspower.com.au

Telephone:+61 2 8005 6688

Website: www.alpspower.com.au

Appendix Connection Options with Inverters

Please first check if the planned configuration is already released according to the latest Battery-Box HVS+&HVM+ Compatible Inverter List before the installation.

Connection with Fronius

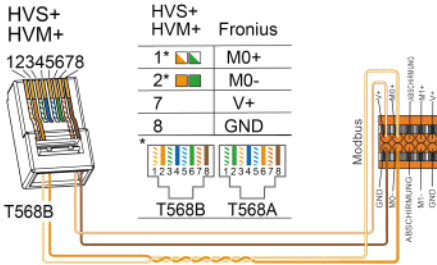

Symo Gen24 Plus / Primo Gen24 Plus

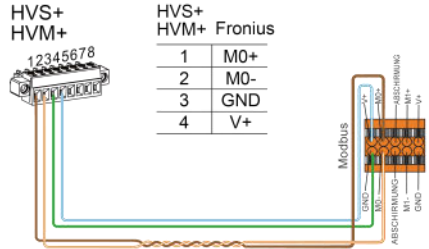

Connection with Kostal

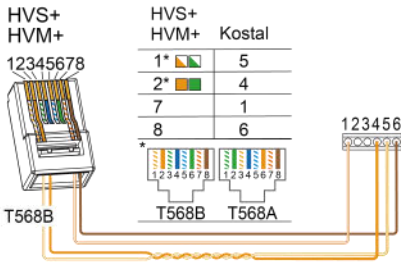

PLENTICORE plus / G2 PLENTICORE BI xx/26 G2 PLENTICORE G3 / PLENTICORE MP G3

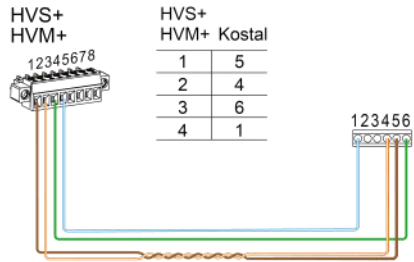

! For Kostal inverter, the type of data cable need Cat7.

Connection with Kaco

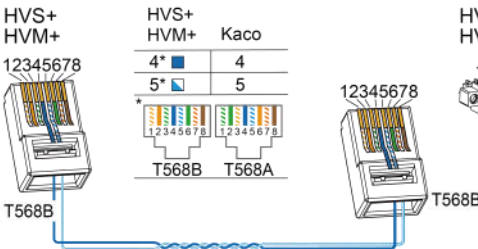

Blueplanet hybrid 6.0 NH3 M2 Blueplanet hybrid 8.0-12.0 NH3 M3

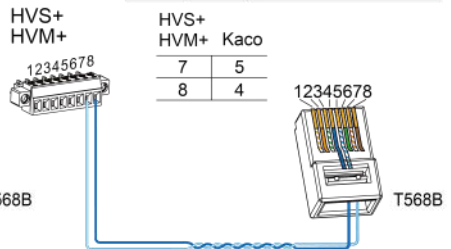

Connection with Solis

S6-EH3P(3-10)K-H-EU / S6-EH3P(5-10)K2-H / S6-EH3P(12-20)K-H
 S6-EH3P(8-12)K-LV-ND-H / S6-EH3P(12-20)K-ND-H / S6-EH3P(29.9-50)K-H

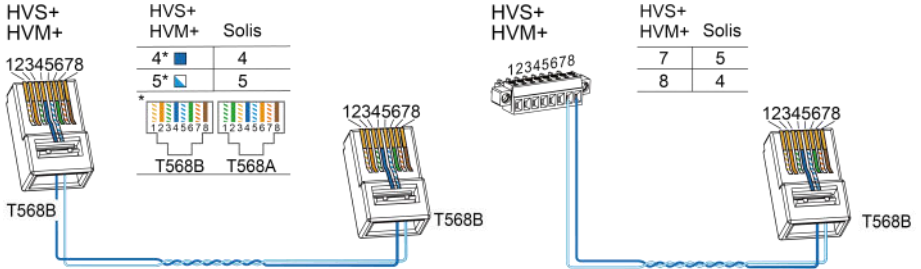

Connection with Goodwe

ET (15-30kW) / ET G2

